

# Queuing Models for Long Term Care Wait Time Reduction & Capacity Optimization: A Nova Scotia Study

By  
Louisa Hallal

A Thesis Submitted to Saint Mary's University  
in Partial Fulfillment of the Requirements for  
the Degree of Master of Science in Applied Science

June, 2015, Halifax, Nova Scotia

© Copyright Louisa Hallal, 2015

Approved: Dr. Michael Zhang  
Supervisor  
Sobey School of Business

Approved: Dr. Jenny Chen  
External Examiner  
Rowe School of Business

Approved: Dr. E. Kevin Kelloway  
Supervisory Committee Member  
Saint Mary's University

Approved: Dr. Hai Wang  
Supervisory Committee Member  
Sobey School of Business

Approved: Dr. Kai Ylijoki  
Defense Chair  
Faculty of Graduate Studies and Research

Date: June 11, 2015



# Abstract

## Queuing Models for Long Term Care Wait Time Reduction & Capacity Optimization: A Nova Scotia Study

By Louisa Hallal

Abstract: As Nova Scotia's society ages, more personal and health care will be needed for people who require assistance to function; thus, policymakers face the challenge of balancing the fiscal burden with the need to ensure that seniors with long term needs receive proper care. This is a challenge best to be confronted before the wave of baby boomers begins to draw on long term care programs in few years. As this happens, demand to access long-term care increases. Also, waiting times escalate and alternative level of care is crowded, due to insufficient beddings in long-term care facilities.

Keeping patients waiting too long could result in waiting costs to them; providing too much service to operate a system with less waiting time involves excessive capacity costs. However, not providing enough service capacity results in excessive waiting time and cost. This research presents models that seek to solve the long waiting time challenge in long term care system in Nova Scotia by finding the optimum capacity allocation. First, an analysis on data from the Department of Health Wellness is done to observe the difference in turnover rate and waiting time between different District Health Authorities in Nova Scotia. Second, using two different approaches, a Markov Chain model is used to reduce long-term care waiting time in Nova Scotia. Third, focusing on a case of a nursing home, a M/M/s queuing model is used to optimize the waiting time and resource allocation combination using scenario analysis, a detailed cost model is provided. The accuracy and behaviour of the queuing models are tested through simulation models and our results, comparisons, policy insights, recommendations, and conclusions are provided.

June 11, 2015

# Acknowledgement

This thesis would not have been possible without the guidance and the help of several individuals who in one way or another contributed and extended their valuable assistance in the preparation and completion of this study.

First and foremost, I would like to acknowledge the patient support, encouragement and advice I received from my supervisor *Dr. Michael Zhang* through this research. I am truly thankful to him for guiding me through the completion of my thesis.

I would like to thank the supervisory committee, *Dr. Jenny Chen, Dr. Hai Wang, and Dr. E. Kevin Kelloway* for their valuable comments and suggestions.

I would like to thank *Dr. Jiejian Feng* for the valuable help and guidance he offered me.

I would like to thank the *Nova Scotia's Department of Health and Wellness (DHW)*, special thanks to *Sankarsingh, A. Perry* for providing the data that allowed me to undertake this research.

I would like to thank *Saint Mary's University* for providing me the opportunity to pursue the MSc in Applied Science program. I am thankful for the support provided by the other members of the *Sobey School of Business*.

I wish to express my gratitude and love to *my family*. Many thanks to *my sister and my brothers* for their understanding patience, through the duration of my studies. Special thanks to *my parents* for teaching me the value of higher education; this is something that I hope to be able to teach to my own children.

Finally, I must express my gratitude to *my husband*, for his continued support and encouragement on a daily basis, and for constantly watching over me.

# Contents

**Abstract i**

**Acknowledgment ii**

**Contents iii**

**List of Tables x**

**List of Figures xiii**

<b>Chapter 1: Introduction .....</b>	<b>1</b>
1.1. Introduction & Background .....	1
1.2. Motivation .....	8
1.3. Contribution .....	8
1.4. Problem Statement & Objective .....	9
1.5. Thesis Organisation .....	10
<b>Chapter 2: Continuing Care System in Nova Scotia .....</b>	<b>11</b>
2.1. Defining Seniors .....	11
2.2. Canada's Senior's Health Status .....	11
2.3. What is Continuing Care? .....	12
2.4. Nova Scotia's Continuing Care System Review .....	13
2.5. Nova Scotia's Long Term Care System Review .....	14
2.5.1. Nursing Homes .....	14
2.5.2. Residential Care Facilities .....	14
2.5.3. Community Based Options .....	14

2.6. Home Care and Visiting Nursing Support System .....	16
2.6.1. Home Support.....	16
2.6.2. Visiting Nursing .....	16
Acute Home Care .....	16
Chronic Home Care.....	16
Palliative Home Care.....	17
2.7. Alternative Level of Care Profile.....	18
2.7.1. ALC in Canada .....	18
ALC Discharge Destinations in Canada.....	19
2.7.2. ALC in Atlantic Canada .....	20
ALC Seniors' Health Conditions in Atlantic Canada.....	20
ALC Discharge Destinations in Atlantic Canada.....	21
ALC Costs in Atlantic Canada .....	22
ALC Waiting Time, Length of Stay in Atlantic Canada .....	23
2.7.3 ALC Challenge.....	24
<b>Chapter 3: Queuing Theory.....</b>	<b>26</b>
3.1. Theoretical Foundation of Queuing Models .....	26
3.1.1. Definitions & Structure.....	26
3.1.1.1. Queuing Theory & Queues.....	26
3.1.1.2. Basic Structure.....	27
3.1.2. Queuing System Characteristics .....	27
3.1.2.1. Input Source (Population Source) .....	28
3.1.2.2. Number of Servers.....	28

3.1.2.3. Types of Queuing Systems.....	28
Single Queue – Single Channel – Single Phase System.....	28
Single Queue – Single Channel – Multiple Phase System.....	29
Single Queue – Multiple Channels – Single Phase System.....	29
Single Queue – Multiple Channels – Multiple Phase System .....	30
Multiple Queues – Single Channel – Single Phase System.....	31
Multiple Queues – Single Channels – Multiple Phase System.....	31
Multiple Queues – Multiple Channels – Single Phase System.....	32
Multiple Queues – Multiple Channels – Multiple Phase System .....	32
Arbitrary Topology of Queues.....	33
3.1.2.4. Arrival Pattern .....	33
3.1.2.5. Service Pattern.....	34
3.1.2.6. Queue Discipline .....	34
3.1.2.7. Queue Characteristics & Behaviour .....	34
3.1.3. Notations of Queuing Models .....	35
3.1.3.1. Queuing Model Classification: Kendall’s Notation .....	35
3.1.3.2. Terminology & Notations.....	36
3.1.4. Queuing Models .....	37
3.1.4.1. Birth and Death Process Models (Exponential Distribution) .....	37
Models with Infinite Queue (Waiting Room): M/M/s Model .....	38
Models with Finite Calling Population: M/M/s Model .....	39
Models with Finite Queue (Waiting Room): M/M/s/K Model .....	40
3.1.4.2. Models with Non-Exponential Distribution .....	41

Models with Infinite Queue.....	41
Models with Poison Input: M/G/s, M/D/s, M/E <sub>K</sub> /s .....	41
Models with Poison Output: GI/M/s, D/M/s, E <sub>K</sub> /M/s .....	42
Models without a Poison Distribution: E <sub>m</sub> /E <sub>k</sub> /s, E <sub>K</sub> /D/s, D/E <sub>k</sub> /s, GI/G/s .....	42
Models with Finite Queue: M/G/s/k, GI/G/s/k Model .....	42
3.1.4.3. Priority Models.....	43
3.1.4.4. Fork-Join Models.....	44
3.1.5. Queuing Networks.....	45
3.1.5.1. System of Infinite Queues.....	45
3.1.5.2. Jackson's Networks.....	46
3.1.5.3. Gordon-Newell Networks.....	47
3.1.5.4. Kelly's Network.....	47
3.1.5.5. The BCMP Networks.....	47
3.2. Queuing Theory in Healthcare.....	47
3.2.1. Queuing Theory Applications in Healthcare .....	48
3.2.1.1. Emergency Room Arrivals.....	48
3.2.1.2. Walk in Physician Offices & Hospitals Clinics .....	48
3.2.1.3. Hospital Pharmacy & Pharmacy Stores .....	49
3.2.1.4. Health Care Resource & Infrastructure Planning.....	49
3.2.1.5. Public Health .....	50
3.2.2. Queuing Theory & Healthcare Capacity Planning .....	50
3.2.3. Measures of Healthcare Queuing System Performance.....	51
3.2.4. Queuing Models in Healthcare Literature.....	51



3.2.4.1. Waiting Time & Utilization Analysis.....	52
Reneging .....	52
Variable Arrival Rate .....	52
Priority Queue Discipline .....	53
3.2.4.2. System Design .....	54
Blocking .....	54
Minimize Costs.....	54
3.2.4.3. Appointment Systems.....	54
Bottlenecks .....	55
System Size .....	55
3.2.5. Alternative Level of Care & Long Term Care in the Literature .....	55
<b>Chapter 4: Long Term Care Analysis in Nova Scotia .....</b>	<b>58</b>
4.1. Data Analysis .....	58
4.1.1. Question 1: Whether 9 District Health Authorities (DHAs) have different turnover rates on beds in: NHs, RCFs, and combination of (NHs and RCFs)? .....	61
4.1.1.1. In Nursing Homes (NHs) .....	61
4.1.1.2. In Residential Care Facilities (RCFs) .....	62
4.1.1.3. In Nursing Homes and Residential Care Facilities (NHs and RCFs) .....	63
4.1.1.4. Discussions .....	64
4.1.2. Question 2: Whether 9 District Health Authorities (DHAs) have different waiting time for the combination of (NHs and RCFs)?.....	69
4.1.2.1. Solution Steps .....	70
4.1.2.2. Discussions .....	71

4.1.3. Question 3: Whether the turnover rate relates to coefficient of variation in NH, RCF, and the combination of NH and RCF? .....	74
4.1.4. Question 4: Whether the turnover rate relates to proportion between the number of beds in NH and RCF? .....	74
4.2. Vacant Beds Causes & Barriers Identified by NHs Providers.....	77
4.3. LTC Admission-Discharge-Transfer Policy .....	79
<b>Chapter 5: Queuing Models for Long Term Care Optimization .....</b>	<b>81</b>
5.1. Method I: Using Markov Chains .....	82
5.1.1. Model Description .....	82
Expanding Approach .....	83
Shunting Approach .....	83
The Model with Poisson Process and Constant Service Rate: M/D/s .....	84
The Model with $(Q_1, Q_2)$ System: A Finite State Discrete Markov Chain.....	85
5.1.2. Model Application.....	87
Parameters Definition .....	87
5.1.3. Simulation Results.....	93
5.1.4. Study of Different Scenarios .....	95
5.2. Method II: Using Queuing Models .....	98
5.2.1. Assumptions .....	99
5.2.2. Scenario Analysis .....	101
Base Case Scenario.....	101
Change in (Capacity/Serving Rate) Scenario .....	104
Change in Arrival rate/Demand Scenario.....	106

Mixed Policy Scenario .....	107
Analysis Conclusion .....	110
5.3. Cost Model .....	111
M/M/s Model Test .....	113
M/D/s Model Test .....	115
<b>Chapter 6: Conclusion .....</b>	<b>118</b>
6.1. Contributions & Results .....	118
6.2. Government Actions and Options on Continuing Care .....	119
6.2.1. The Build More Option .....	119
6.2.2. The Integrated Care Option .....	121
6.2.3. The Financial Incentives Option .....	122
6.3. Recommendations and Solutions .....	123
6.3.1. Adopt a Province Wide “Home First” Plans .....	123
6.3.2. Adjust the Discharge Planning Process .....	124
6.3.3. Improve Gaps in Provider-to-Provider Communication .....	125
6.3.4. Recommendations List .....	126
6.4. Suggestions for Future Work .....	130
6.4.1. An Open Jackson Queuing Network .....	131
6.4.2. Queuing Network Assumptions .....	132
<b>References .....</b>	<b>133</b>
<b>Appendix A: DHAs &amp; Areas in Nova Scotia .....</b>	<b>142</b>
<b>Appendix B: Acronyms &amp; Abbreviations .....</b>	<b>143</b>
<b>Appendix C: Definitions Glossary .....</b>	<b>144</b>

# List of Tables

## Chapter 2

<b>Table 2.1:</b> NS continuing care in numbers, 2010–2014.....	15
<b>Table 2.2:</b> Home - Community based programs, Nova Scotia .....	17
<b>Table 2.3:</b> Seniors discharged from acute care with ALC days, Canada, 2007- 2011 .....	18
<b>Table 2.4:</b> ALC days' by discharge destination, Atlantic Canada 2008-2009.....	22
<b>Table 2.5:</b> Average cost of patients' acute care, Atlantic Canada, 2009-2010 .....	23
<b>Table 2.6:</b> Average waiting days for LTC, ALC in Nova Scotia.....	24

## Chapter 3

<b>Table 3.1:</b> % of ALC patients re-admitted within 30 days of discharge to home.....	56
--	----

## Chapter 4

<b>Table 4.1:</b> Number of beds in nursing homes (NHs) in 9 districts.....	59
<b>Table 4.2:</b> Number of beds in Residential Care Facilities (RCFs) in 9 districts .....	60
<b>Table 4.3:</b> Number of placements in 9 DHAs, 2011-2014.....	61
<b>Table 4.4:</b> Turnover rate in NHs .....	61
<b>Table 4.5:</b> Tukey-Kramer method test results for NHs.....	62
<b>Table 4.6:</b> Turnover rate in RCFs .....	62
<b>Table 4.7:</b> Tukey-Kramer method test results for RCFs .....	63
<b>Table 4.8:</b> Turnover rate in NHs and RCFs .....	63
<b>Table 4.9:</b> Tukey-Kramer method test results for NHs and RCFs.....	64
<b>Table 4.10:</b> Research results on LTC patients (75+) in Nova Scotia, 2009-2010 .....	65
<b>Table 4.11:</b> LTC waiting list (Hospital, Community, Transfer) .....	68

<b>Table 4.12:</b> Number of weekly patients pending placement for a NH or RCF.....	69
<b>Table 4.13:</b> Tukey-Kramer method test results for waiting time in NHs and RCFs.....	71
<b>Table 4.14:</b> One-way ANOVA test results for 9 DHAs .....	71
<b>Table 4.15:</b> Population in Nova Scotia and DHAs, 2011 .....	76

## **Chapter 5**

<b>Table 5.1:</b> Method I parameters definitions I.....	92
<b>Table 5.2:</b> Method I parameters definitions II .....	93
<b>Table 5.3:</b> M/M/s cost model results.....	113
<b>Table 5.4:</b> M/D/s cost model results 1 .....	115
<b>Table 5.5:</b> M/D/s cost model results 2 .....	116
<b>Table 5.6:</b> Comparison between M/M/s and M/D/s cost models results .....	117

# List of Figures

## Chapter 1

<b>Figure 1.1:</b> Global population pyramid during 2002–2025 .....	1
<b>Figure 1.2:</b> Canadian population 2009, 2036, 206.....	2
<b>Figure 1.3:</b> Canada’s population composition, by age, 1971–2051.....	3
<b>Figure 1.4:</b> Canada’s projected seniors’ proportions by province/territory 2010–2030.....	4
<b>Figure 1.5:</b> Nova Scotia’s population 2009, 2036 .....	4
<b>Figure 1.6:</b> Number of clients waiting for long-term care, 2011-2014.....	6
<b>Figure 1.7:</b> ALC by province 2007–2008 .....	7

## Chapter 2

<b>Figure 2.1:</b> Home care services, Nova Scotia .....	17
<b>Figure 2.2:</b> Seniors discharge destinations, ALC, Canada, 2009-2010 .....	20
<b>Figure 2.3:</b> CMG+ for patients discharged with ALC days, Atlantic Canada.....	21
<b>Figure 2.4:</b> Discharge Destinations of ALC Patients, Atlantic Canada, 2009-2010 .....	22

## Chapter 3

<b>Figure 3.1:</b> The basic queening system.....	27
<b>Figure 3.2:</b> Single queue, single channel, single phase system .....	29
<b>Figure 3.3:</b> Single queue, single channel, multiple phase system.....	29
<b>Figure 3.4:</b> Single queue, multiple channels, single phase system .....	30
<b>Figure 3.5:</b> Single queue, multiple channels, multiple phase system .....	30
<b>Figure 3.6:</b> Multiple queue, single channel, single phase system.....	31
<b>Figure 3.7:</b> Multiple queue, single channel, multiple phase system .....	31

<b>Figure 3.8:</b> Multiple queue, multiple channels, single phase system .....	32
<b>Figure 3.9:</b> Multiple queue, multiple channels, multiple phase system.....	32
<b>Figure 3.10:</b> Arbitrary topology of queues .....	33
<b>Figure 3.11:</b> Rate diagram for the birth and death process .....	37
<b>Figure 3.12:</b> Rate Diagrams for the infinite M/M/s model .....	39
<b>Figure 3.13:</b> Rate diagrams for the finite M/M/s model .....	40
<b>Figure 3.14:</b> Priority queuing system.....	44
<b>Figure 3.15:</b> Fork-join queuing system.....	45

#### **Chapter 4**

<b>Figure 4.1:</b> Average waiting time across NS (Hospital, Community, Transfer), 2014 ....	73
<b>Figure 4.2:</b> Waiting times for hospital and community clients, NS, 2009-2011 .....	74
<b>Figure 4.3:</b> Nova Scotia's DHAs population, by age Groups, 2011 .....	75
<b>Figure 4.4:</b> Life expectancy in Nova Scotia, by Birth/Age 65, by DHA.....	77

#### **Chapter 5**

<b>Figure 5.1:</b> Long term care system in Nova Scotia.....	81
<b>Figure 5.2:</b> The average waiting time of case ( $\alpha(60), 900, 2575$ ) .....	94
<b>Figure 5.3:</b> The average waiting time for case ( $\alpha(40), 900, 2575$ ) .....	96
<b>Figure 5.4:</b> The average waiting time for case ( $\alpha(120), 900, 2575$ ) .....	97
<b>Figure 5.5:</b> Method II: One Nursing Home Queuing model.....	98
<b>Figure 5.7:</b> Scenario analysis results, base case scenario 1 .....	103
<b>Figure 5.8:</b> Scenario analysis results, base case scenario 2 .....	103
<b>Figure 5.9:</b> Scenario analysis results, capacity/serving rate change scenario 1 .....	104

<b>Figure 5.10:</b> Scenario analysis results, capacity/serving rate change scenario 2.....	105
<b>Figure 5.11:</b> Scenario analysis results, arrival rate/demand change scenario.....	107
<b>Figure 5.12:</b> Scenario analysis results, mixed policy scenario 1 .....	108
<b>Figure 5.13:</b> Scenario analysis results, mixed policy scenario 2 .....	109
<b>Figure 5.14:</b> Scenario analysis conclusion.....	110
<b>Figure 5. 15:</b> Queuing healthcare system associated waiting and capacity costs .....	111
<b>Figure 5.16:</b> M/M/s cost model results .....	113
<b>Figure 5.17:</b> M/D/s cost model results.....	115

## **Chapter 6**

<b>Figure 6.1:</b> Nova Scotia’s ALC/LTC actions (Continuing Care Strategy) .....	121
<b>Figure 6.2:</b> An open Jackson network for LTC in NS .....	132



# Chapter 1

## Introduction

### 1.1. Introduction & Background

Aging global population changes the nature of health care systems by increasing demands on social and health services. Thus, pushing governments to finance these services and accommodate the care-needs of elderly population and other population age groups [1].

Worldwide, the proportion of elderly people (age 60 and over) is growing faster than any other age group. It is expected that between 1970-2025, older population growth percentage will be by 223% (or an addition of 694 million). In 2025, there will be a total of about 1.2 billion people over the age of 60 and by 2050 there will be 2 billion [2].

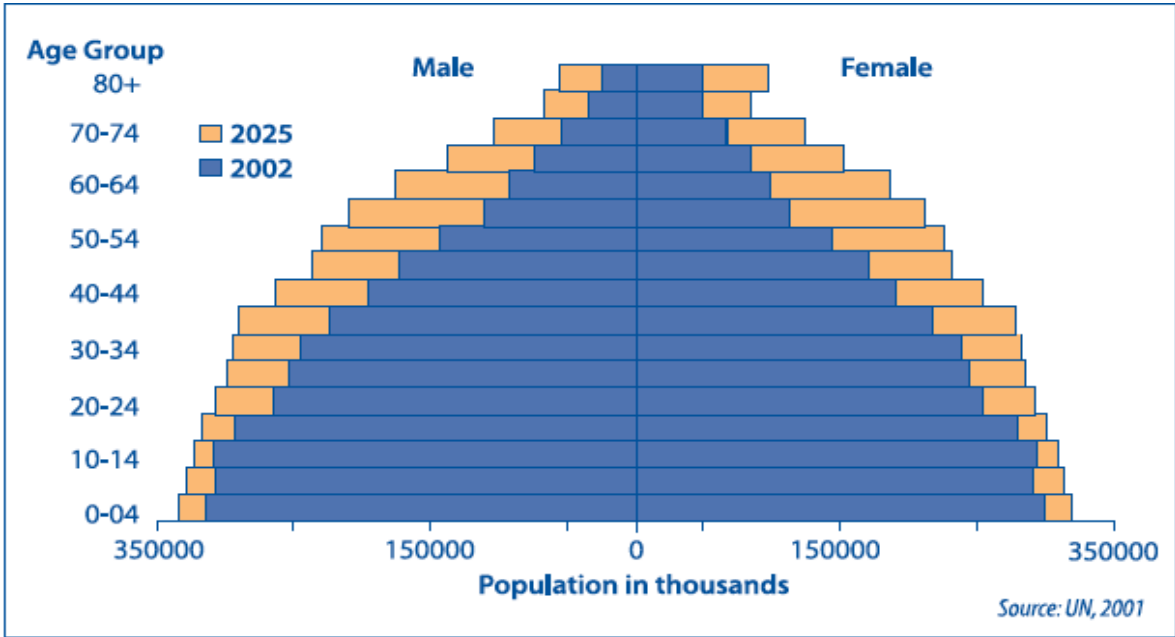
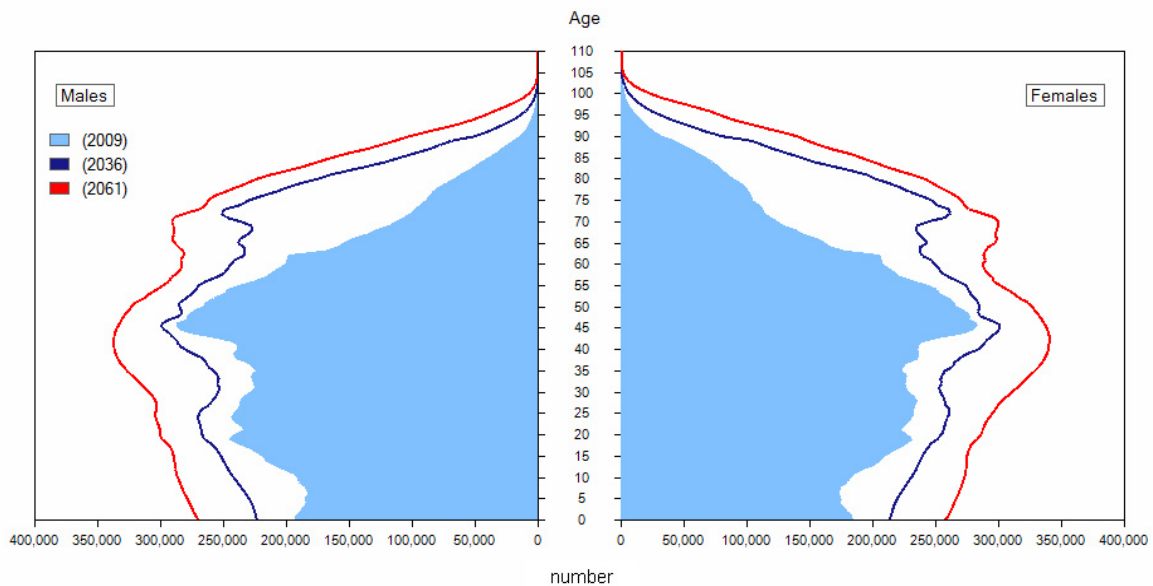

Figure 1.1: Global population pyramid during 2002–2025 [2].

Source: United Nations, 2001

In Canada, over the past few decades, the increasing life expectancy and the decreasing birth rate have resulted in an aging population. Thus, seniors (age 65 and over) account for a growing proportion of the Canadian population. Between 1986-2010, the number of seniors increased from 2.7 million to 4.8 million and from 10% to 14% of the total population. Between 2011-2031, all members of Canada's largest birth cohort (the baby boom generation born between (1946-1965) will turn 65. As a result, the number and proportion of seniors in the population will climb. After 2031, population aging is expected to continue, but at a less rapid pace [3].

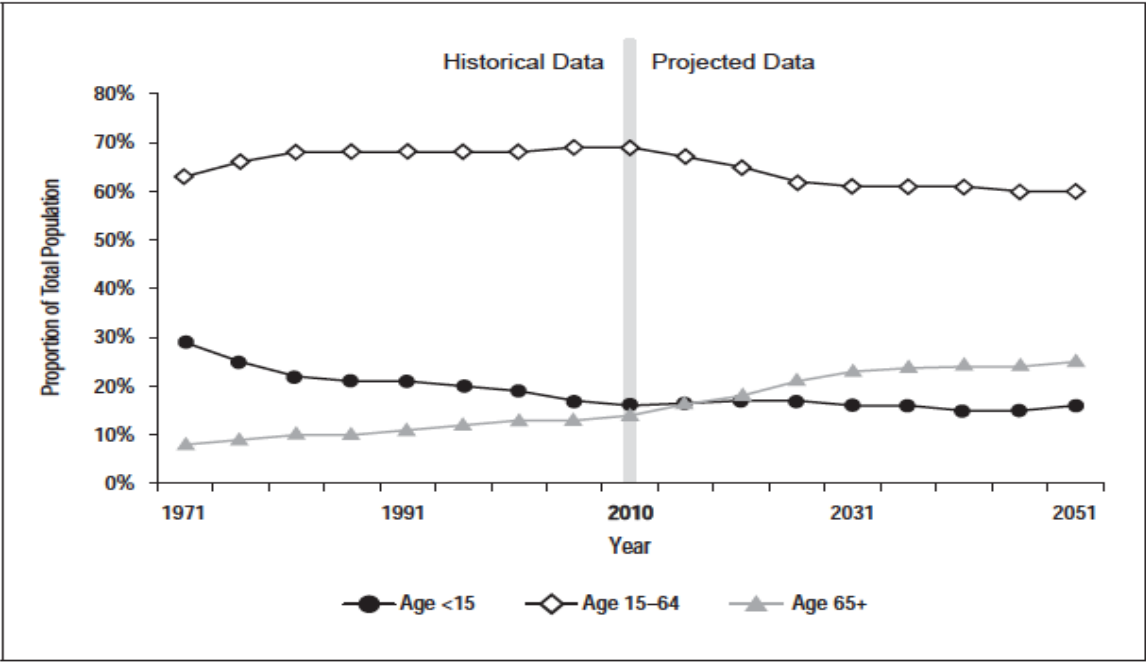

**Figure 1.2:** Canadian population 2009, 2036, 2061 [4].

Source: Statistics Canada, Demography Division

Most of Canada's seniors are in the youngest age group (65-74), but the proportion of the most elderly seniors (85 and over) is growing rapidly. In 2010, about 53% of seniors were between (65-74), 33% were between (75-84), and 13% were (85 and over). This last group accounted for 2% of the total Canadian population in 2011. It is expected that in 2031, the proportion of seniors (age 65-74) will decline, but those aged (85 or over) will

stay the same and represent 3% of the total Canadian population. By 2052, these proportions will nearly double: the eldest seniors (85 and over) will account for 24% of all seniors and 6% of the total population. Moreover, most seniors are women. In 2010, women accounted for 52% of seniors aged (65-74) and 60% of those aged (75 and over) [3].



**Figure 1.3:** Canada’s population composition, by age, 1971–2051[3].  
Sources Statistics Canada 2010

All provinces and territories across Canada are having an increase in the elderly population. The Atlantic Provinces currently have the highest proportions of seniors (15% to 16%), while the territories account for the lowest (3% to 8%). By 2031, the greatest increases will occur in both the Atlantic Provinces and in the territories [3].

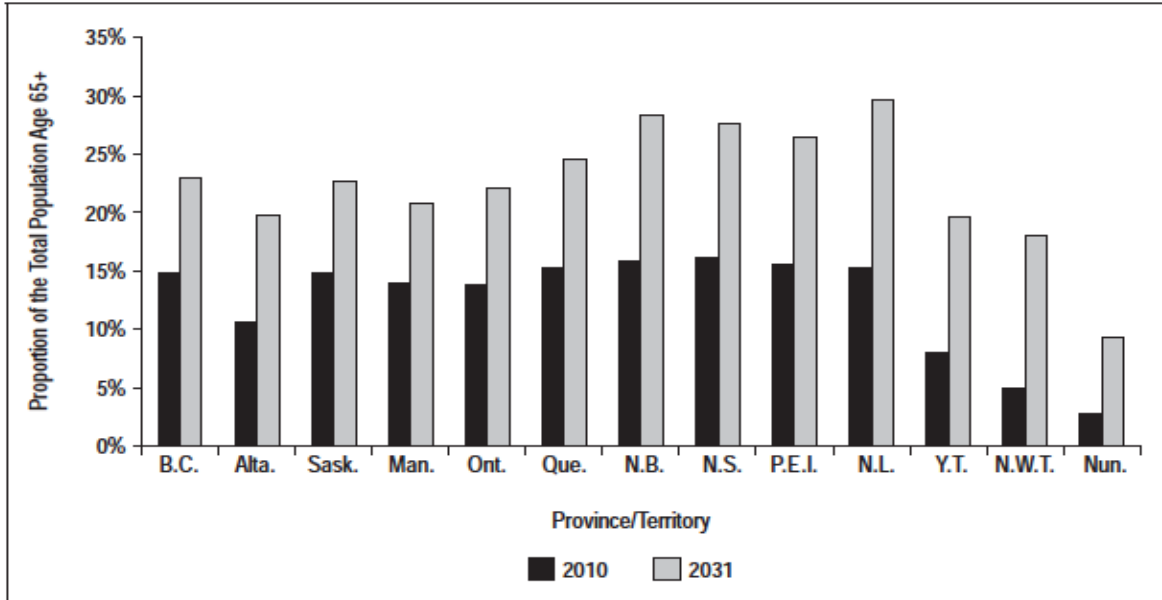

**Figure 1.4:** Canada’s projected seniors’ proportions by province/territory 2010–2030 [3].

Source: Statistics Canada 2010

Nova Scotia holds the highest number of seniors (age 65 and over) with 16.5% of its total population. This number is expected to increase rapidly and reach more than 30% by the year 2021 [5].

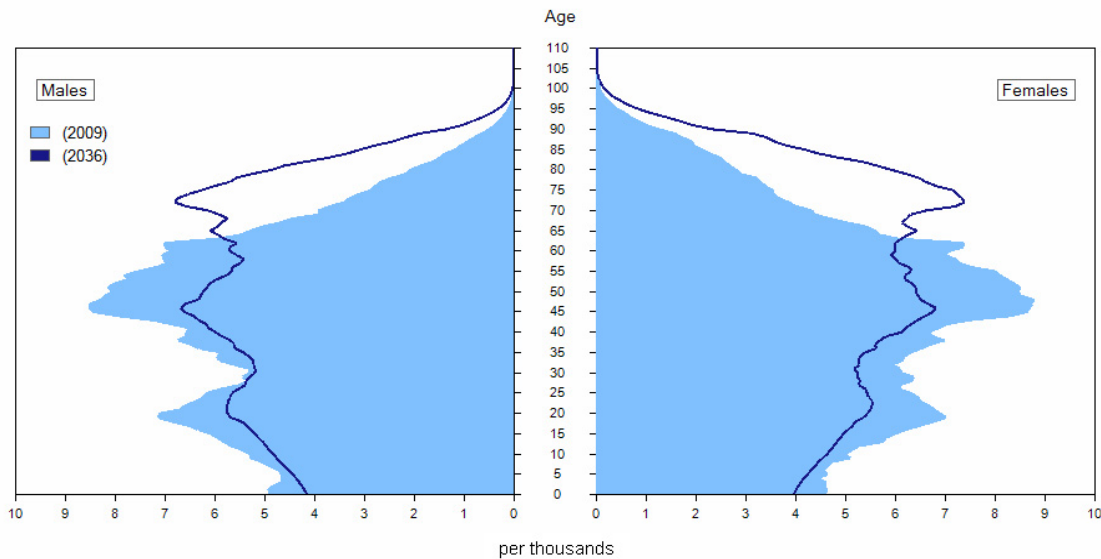

**Figure 1.5:** Nova Scotia’s population 2009, 2036 [4].

Source: Statistics Canada, Demography Division

According to CBC News (2011): In Nova Scotia, some seniors wait more than a year to get into a LTC facility, and the waits are getting longer [6]. However, the usual waiting time for a bed in a LTC facility in Nova Scotia varies between (86–238) days [7]. According to the Department of Health and Wellness (2013), the longest wait for a long-term care bed is in the Cape Breton district, where the median wait is about 13 months (396 days) to get into a nursing home and about seven months (193 days) to get into a residential care facility. In Capital Health, the median wait is about six months (186 days) for a nursing home and just over five months (156 days) for a residential care facility [8].

In 2006, the provincial government introduced a 10-year plan for continuing care in Nova Scotia. The plan includes economical and flexible programs such as homecare, respite care, palliative care, and also a creation of (1320-1595) new long-term care beds over 10 years. Since then, nearly 1000 new long-term beds have opened and total LTC capacity increased by 13%. In 2013, the health authorities kept adding only few extra LTC beds around the provincial districts (from 2 to 15 bed per district), but now the government is not willing to build any extra LTC beds for those on the waiting list and is looking for a better alternative long term solution. Currently Nova Scotia has 7821 LTC beds [6, 8, 9].

Despite the added LTC beds that we previously mentioned, the LTC beds demand exceeded the supply; thus, the waiting list continues to grow. The waiting list for LTC increased by 35.5%: around 900 people waiting for long-term care beds in 2006 and 1284 people in 2007, increased to approximately 1740 people in 2010 [6,9]. In 2012, around 2400 seniors were waiting for LTC bed in Nova Scotia with an increase of 50% [8]. In 2013, around 2551 seniors are waiting [10]. Currently, 2575 seniors are waiting [11].

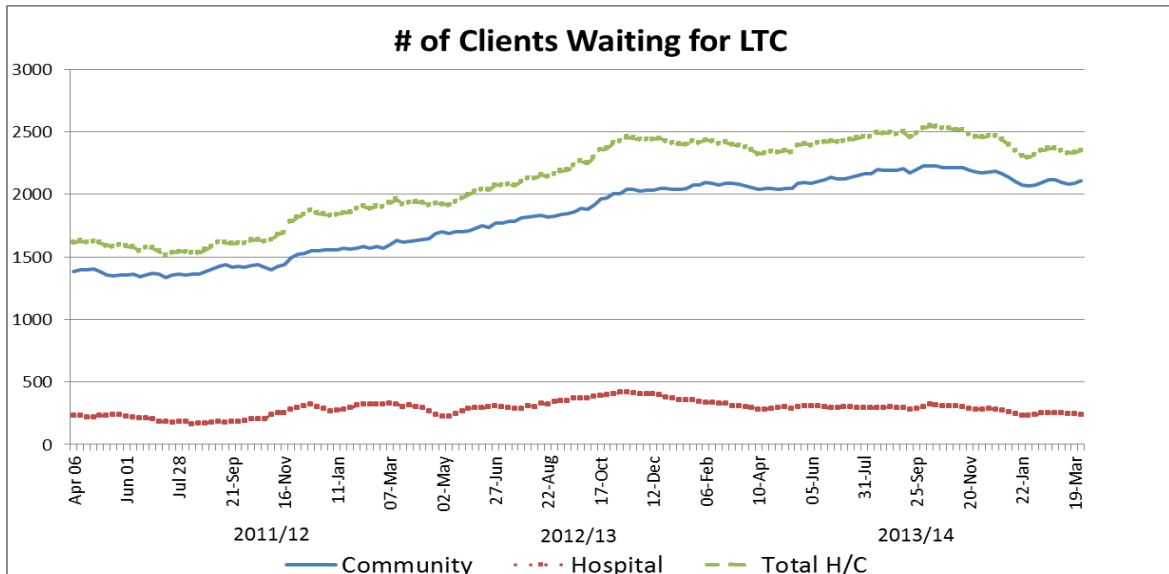

**Figure 1.6:** Number of clients waiting for long-term care, 2011–2014 [12].

Source: Department of Health and Wellness

According to Nova Scotia’s Provincial Budget report, in 2014, Nova Scotia’s net debt is estimated to be \$14.6 billion, the healthcare system budget will top \$4 billion with \$32.6 million reserved to support home care services [13,14]. In another hand, and according to Nova Scotia’s Department of Health and Wellness (2013), the total annual cost to provide LTC in the province is about \$669 million [8]. Daily homecare support is only \$33/day compared to the expensive daily cost of \$300 for LTC [9]. As a result, Nova Scotia’s government is keeping with the plan that providing any extra LTC beds is not a feasible solution, and focusing on supporting home care as a an alternative supportive solution to LTC waiting list. Why is that? They believe that they could never build beds fast enough to meet the growing senior population. Plus, seniors prefer to stay home longer, and doing so would be beneficial for seniors’ wellbeing and for cutting LTC budget and capacity on the long run.

By the rising demand for LTC and not supporting the LTC crisis, the government is allowing the wait list to grow and grow; thus, hospitals are being unable to discharge and

forced to keep patients that no longer require acute care services in acute care beds, waiting for a placement in a more appropriate LTC facility. This is crowding emergency rooms and services in some communities [8,15]. This challenge has led to the designation of “alternative level of care” (ALC) being ascribed to “people who have completed the acute care phase of their treatment but remained in an acute care bed due to insufficient capacity downstream”[15,16].

In Canada (2007–2008), ALC patients accounted for 5% of hospitalizations and occupied 5200 beds in acute care hospitals (14% of hospital days in acute facilities) [17].

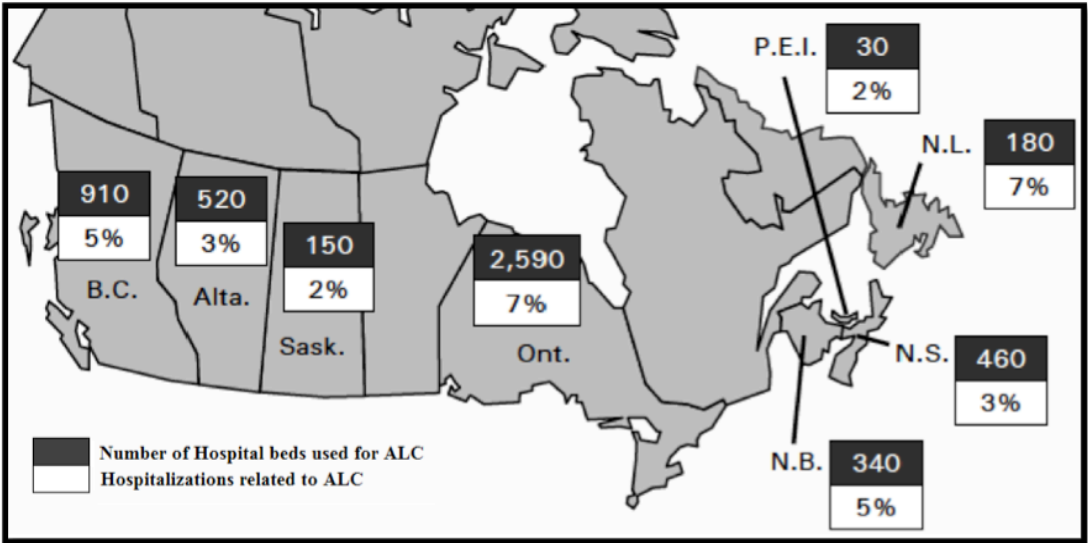

**Figure 1.7:** ALC by province 2007–2008 [17].

Source: Discharge Abstract Database, Canadian Institute for Health Information 2007–2008

Evidence suggests that seniors in ALC waiting to be discharged may experience decline in their overall health and wellbeing [15]. Some people seem to wait a tremendous long time and there are cases of affiliating somebody to a facility at a long distance away from a spouse/other family members [8].

## 1.2. Motivation

Population ageing raises many fundamental questions for policy-makers. How to help seniors remain independent and active as they age? Is it possible to strengthen senior health prevention and care policies? Can seniors' life quality be improved as their life expectancy is increasing? Will senior care long waiting list bankrupt the health care and social support systems? How to balance the family/state role in regard to caring for people who need assistance?

This thesis is designed to address some of these questions and other concerns about senior care waiting line crisis. It targets government decision-makers responsible for the formulation of policies and programs on ageing. It approaches seniors' health care crisis from a broad perspective and acknowledges the fact that it can be resolved by the participation of multiple sectors. It suggests that both health care providers and families must team up to achieve the goal of healthy older persons.

## 1.3. Contribution

The performance of any healthcare system is measured by its capacity and waiting costs optimisation. This is especially more important in a healthcare system that involves seniors competing for the same pool of resources and moving through the system facilities in a very slow rhythm.

This thesis presents queuing models that aim to reduce senior's long-term care list waiting time. This is done through an investigation of Nova Scotia's LTC care system and the different factors/causes that aggravate and prolong its waiting time. First, an analysis on real gathered data is done. Second, different queuing models were applied on Nova Scotia's long-term care to observe how the changes in system parameters effect the waiting time. Third, a



cost model is developed to better allocate the resources. Last, some effective recommendations toward a more cost-time effective system are suggested.

The goal of this research is to aid researchers, care providers, health systems stakeholders, and policy/system decision makers in making the best decision possible to upgrade Nova Scotia's LTC system. Thus, Nova Scotia's seniors' health and wellbeing will prosper.

## 1.4. Problem Statement & Objective

Here are two tragic stories about Canadian seniors that may sum up the problem:

"Al and Annie Albo had been married for nearly 70 years when Annie (aged 91) lay dying with congestive heart failure in the KBR Hospital, BC. Al (aged 96) was also sick in the hospital. In February 17, Annie was wheeled into her husband's room and asked to say goodbye. She was being transferred to a nursing home in Grand Forks 100 miles away. Hospital staff had strapped Annie to the wheelchair, so she was not able to embrace her husband in the few moments before they took her away. She died alone two days later. Al died thirteen days after that". When the newspapers broke the story, a wave of outrage swept the province: Angry letters to the editor, negative television coverage, unhappy patients' family numbers...etc [18].

"Nancy Davis and Jean Reynolds, two senior sisters living in Three Mile Plains, N.S., made the decision to move their older, ailing sister Shirley to a nursing home. Reynolds told CBC News that: "It's not that we don't love our sister. We do. But it's hard. It's stressful. We are seniors taking care of a senior. We just can't understand why it is taking so long" [6].

These sad stories illustrate too well the tragic consequences and needless suffering caused by a system in crisis. Countless stories could be told of other seniors and their families who have endured similar indignities in communities across Canada. Stories documenting the neglect of seniors have been in Canada's news headlines for many years. Today, they are familiar and shocking as they were twenty years ago.

The research objective that we seek is: *Understand the impact on long term care wait time and costs for different capacity allocation strategies using analytical modeling approach.*

## 1.5. Thesis Organisation

This thesis is organized as follows:

Chapter 1 (This chapter): Presents the background of long waiting time list in continuing care along with a statement of the research problem.

Chapter 2: This chapter gives a summed up outline of Nova Scotia's continuing care, long-term care, home care and alternative level of care systems.

Chapter 3: This chapter is a review of the different queuing models in the literature and it sums up prior queuing models research in healthcare and long-term care.

Chapter 4: This chapter is a data study and analysis of alternative level of care in Nova Scotia along with a list of recommendations.

Chapter 5: This chapter describes the research methodology, the implemented models, our research results (findings), and discussions are provided.

Chapter 6: This chapter contains the conclusion, solutions and recommendations.

# Chapter 2

## *Continuing Care System in Nova Scotia*

---

### 2.1. Defining Seniors

The Organization for Economic Co-operation and Development (OECD) defines seniors as age 65 and older. However, there is no true specific definition. Some argue that rising life expectancies worldwide mean that age 65 can no longer be regarded as the start of older age. Also, they assert that since people age differently; combining all people age 65 and older into one-category results in a diverse group that doesn't share a lot in common. In Canada, and according to the Canadian Institute of Health Information (CIHI), age 65 is the defining age for seniors. At this age, many Canadians begin to receive social services. Also, it is the mandatory age for retirement in Canada; however, this is no longer the case in most provinces and territories, where many people work well even in their 60s and beyond [3].

### 2.2. Canada's Senior's Health Status

According to a major study undertaken by Statistics Canada from the 1996 General Census, the majority (75%) of seniors in Canada receives assistance in some form. 1.6 M (47%) received assistance as a consequence of the way their households were organized, 128.000 (4%) received care as a result of a temporary difficult time, while 3/4 of a million Canadian seniors (22%), received care as a result of a long term health problem or physical limitation. It is this last mentioned group that poses the most serious challenge on the issue of elder care, as it requires the type of care that is a response to issues of physical or psychological limitations with high levels of need [18].

## 2.3. What is Continuing Care?

Continuing care (CC) is commonly used to denote many continuing forms of care. It does not refer to hospital based continuing care: called Alternative level of care (ALC), which tends to be intense, complex and of shorter duration than long-term residential care. However, it may refer to long-term care residential facilities, home care or assisted living arrangements that provide basic levels of support; with the assumption that the elderly are either (fully or partially) independent, mobile and do not require 24 hour nursing care [19]. In addition, continuing care was defined as an ongoing, indefinite, care for individuals who are no longer able to fully take care of themselves. Continuing care includes both: health care (nursing/medical care), and social services (income supported housing, assistance with daily living activities, and the provision of recreational and social programs) [20]. In Canada, according to [21], continuing care is commonly defined as representing:

“ A range of services that addresses the health, social and personal care needs of individuals who, for one reason or another, have never developed or have lost some capacity for self-care. Services may be continuous or intermittent, but it is generally presumed that they will be delivered for the “long-term” that is, indefinitely to individuals who have demonstrated need, usually by some index of functional incapacity ”.

These definitions are referring that “Continuing care” include all facilities that provide care for the elderly. However, not all of these facilities’ residents are elderly. Many facilities are provided for only children and young adults; that’s because even that their health care needs are similar to the elderly, their social and recreational needs are not [19]. Such facilities and individuals are not the focus of this thesis.

## 2.4. Nova Scotia's Continuing Care System Review

In Nova Scotia, the continuing care sector represents a significant and essential component of the health system. The term continuing care describes a set of long or short term health services programs offered outside of the hospital. These services programs are available to people from all ages and situations depending on their needs. Moreover, these services help people become more independent, improve their health and well being, promote their quality of life, and support families taking care of their loved ones. Sometimes, patients receive support and assessment services at home. The wanted goal is helping people live to the fullest while being at home [22].

Many organizations are involved in the delivery of continuing care. They receive funding from the Department of Health and Wellness; others operate under the Department of Community Services. Continuing care organizations include and can be classified as: Long term care (nursing homes, residential care facilities, and community based options), home care organizations (home support and visiting nursing), services for persons with physical or mental disabilities (regional rehabilitation centers, disability and medical equipment programs, neglect or abuse protection programs) [22, 23].

## 2.5. Nova Scotia's Long Term Care System Review

There are three types of long-term care (LTC) facilities in Nova Scotia, which are: Nursing Homes, Residential Care Facilities and Community-Based Options [24].

### **2.5.1. Nursing Homes**

Nursing Homes (homes for the aged) provide long-term care to persons who are medically stable, but require a high level of nursing care on a 24/7 basis. These facilities provide accommodation, personal care (such as, dressing, bathing and toileting) and professional nursing care that can't be met through home care. In addition, nursing homes offer various programs and supports like: spiritual care, nutrition services, and recreation therapy [22, 25].

### **2.5.2. Residential Care Facilities**

Residential care facilities (RCFs) provide a good option for seniors who need housing, supervision and continuing care. When nursing home care is not required and home care is not appropriate, these care facilities can provide people or adults with disabilities with personal care, support, illness supervision, community skills and activities and accommodation in a safe and supportive environment [22].

### **2.5.3. Community Based Options**

Community based options (CBO) provide similar level of care options to residential care facilities, but serve to a maximum of 4 beds in an approved small home-like supportive environments [22].

The Table below shows a resume of important LTC numbers.

<b>Nova Scotia's Continuing / Long Term Care (LTC) in Numbers</b>	
<b>LTC Beds</b>	7821 bed
<b>Total senior care facilities</b>	217 facilities
<b>Homes for the aged</b>	107 facilities
<b>Mental health facilities</b>	110 facilities
<b>Non profit homes</b>	145 facilities
<b>For profit homes (proprietary)</b>	72 facilities
<b>Nursing homes</b>	87 facilities (6713-6902 beds)
<b>Residential care facilities</b>	37 facilities (820-931 beds)
<b>Community based options</b>	31 facilities (90 beds)
<b>Gender in LTC</b>	71% females
<b>% LTC Seniors ≥ 85 years</b>	43%
<b>Total Provincial LTC cost</b>	\$669 million (\$538 from province, rest from residents)
<b>Annual home care budget</b>	\$196 million (from provincial government)
<b>Daily NH accommodation cost</b>	\$104 per day (≈\$3120/month)
<b>Daily RCF accommodation cost</b>	\$61.50 per day (≈\$1845/month)
<b>Daily CBO accommodation cost</b>	\$50.50 per day (≈\$1515/month)

**Table 2.1:** NS continuing care in numbers, 2010–2014 [8, 19, 26, 27, 28, 29, 30]

**Definitions [26]:**

**Homes for the aged:** Nursing homes, retirement homes, and other facilities providing services and care for the aged. Not included are homes for senior or lodges where no care is provided.

**Mental health facilities:** Facilities for persons with developmental delays, psychiatric disability, alcohol or drug problems and for emotionally disturbed children.

**For profit homes:** Facilities owned by an individual, organizations or corporations operating for a profit.

**Non-profit homes:** Federal, provincial, municipal, religious, volunteer institution operating for no profit.

## 2.6. Home Care and Visiting Nursing Support System

Home care services provide a set of services to people in their homes, helping them live independently and the longest possible within their communities. According to Nova Scotia's department of health and wellness, home care support services include two different sets of services [22, 23, 24, 31]:

**2.6.1. Home Support:** includes assistance with personal care (bathing, dressing, eating and toileting), respite, activities of daily living (light housekeeping, laundry and meal preparation), and family relief/respite help.

**2.6.2. Visiting Nursing:** includes administering medications, dressing changes, intravenous therapy, catheter care, foot care, home oxygen, teaching nursing procedures to family members and other caregivers and palliative care.

Moreover, according to [32], all District Health Authority home care programs should provide acute, chronic, and palliative home care services to patients in need.

### **Acute Home Care**

This service is offered to patients who are recovering from an acute health episode. These patients are in a stable medical condition and can be stabilized with monitoring, or minimal intervention from specialized and skilled nurses, for a short period of time.

### **Chronic Home Care**

Chronic home care is neither acute nor palliative; it is a continuous service that can be classified into supportive care, maintenance care, or rehabilitative care. Chronic home care provides services to those who are chronically ill, disabled, or has limitations due to aging and who need help to have a successful life at home and within the community [23].



## Palliative Home Care

This is an end-of-life service provided to people who are terminally ill, and in situations where life prolongation is no longer the goal.

The Figure below shows different home care services offered in Nova Scotia:

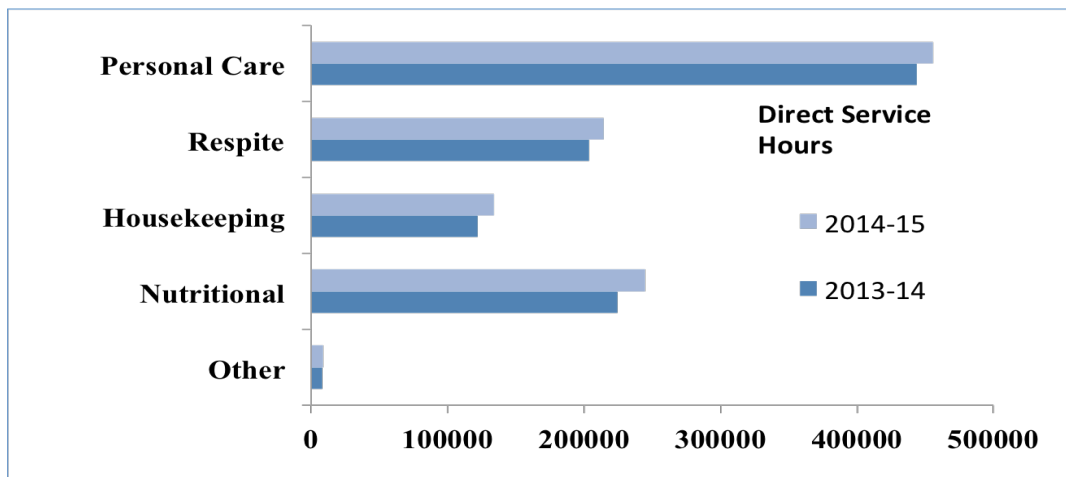

**Figure 2.1:** Home care services, Nova Scotia [33]

There are Community care based-Programs (CCBP) that are different from LTC Community based-Options (CBO) institutions. The Table below shows the different Home/Community based-Programs available for LTC patients in Nova Scotia:

Home & Community based Program	Number of clients October 2014	Number of clients October 2013
<b>Personal Alert Assistance Program</b> Expanded: February 2013	511	239
<b>Caregiver Benefit</b> Expanded: November 2012	1766	1482
<b>Self Managed Care Program</b> Expanded: February 2013	147	147
<b>Supportive Care</b>	222	109
<b>Wheelchair Loan</b> Implemented: November 2013	120	0
<b>Home Oxygen</b> Ended: 2013-2014	1306	1622
<b>Medication Dispenser Program</b> Implemented: February 2013	6	6

**Table 2.2:** Home - Community based programs, Nova Scotia [33]

## 2.7. Alternative Level of Care Profile

The term “Alternate Level of Care” (ALC) is used when a patient is occupying a bed in a hospital and does not require the intensity of resources/services provided in this care setting (Acute, Complex Continuing Care, Mental Health or Rehabilitation) [15, 34]. In the context of this thesis, and according to the Canadian Institute of Health Information, ALC identifies a person who has completed the acute care phase of his/her treatment but remained in an acute care bed.

### 2.7.1. ALC in Canada

In Canada, more than 5200 acute care beds were occupied daily by ALC patients in 2009. That number increased to 7500 (14%) in 2011. In term of resources, the equivalent of 2.4 million hospital days were used over the year (2008-2009). On average, one ALC patient occupying a bed in hospital denies access to four people/hour to the ER. Nearly 85% of ALC patients are age 65 or older; around 35% are older than 85 [35].

During 2009-2010, almost 23% of all ALC seniors had a diagnosis of dementia. Their median length of stay in hospital was more than twice that of seniors without a similar diagnosis (20 vs. 9) days. The increased length of stay was likely due to waiting for an available spot in LTC. About 15% of all ALC stays last only a few days, while 20% lasts more than a month [3, 36].

Discharge destination	Number of ALC patients	% of all ALC patients
Long term care	183.051	53.5%
Home with support	62.738	18.3%
Home without support	35.503	10.4%
Died	38.352	11.2%
Rehabilitation facility	14.518	4.2%
Other	7.957	2.3%

**Table 2.3:** Seniors discharged from acute care with ALC days, Canada, 2007- 2011[15]

## **ALC Discharge Destinations in Canada**

From acute hospitals, patients are discharged to a variety of settings depending on their clinical needs, patient and caregiver preferences and the availability of resources to care for them. Their discharge plan takes into account complex personal and institutional relationships, medical and rehabilitative needs plus psychosocial supports. Matching patients with settings that reflect needs, preferences and resources can be challenging and often results in delayed discharge from hospital [36].

Approximately two-thirds of ALC patients are waiting for a transfer to another healthcare facility. The common ALC discharge destinations in Canada are either [36]:

Facility-based Continuing Care: Facility-based continuing care is the most common discharge location for ALC patients, over 50% of ALC patients are discharged to 24-hour facility based post acute care. Due to their complex needs, at least two-thirds of patients are awaiting discharge to a facility-based bed. The most common types of facility-based continuing care are complex continuing care, long-term care (nursing home, residential care facility), inpatient rehabilitation, and may include facility-based hospice care.

Community-based Continuing Care: Approximately one-third of ALC patients are waiting to be discharged into community-based continuing care. The most common discharge locations are supportive living, low intensity home care services (with and without support services) and community support services. A detailed figure is below.

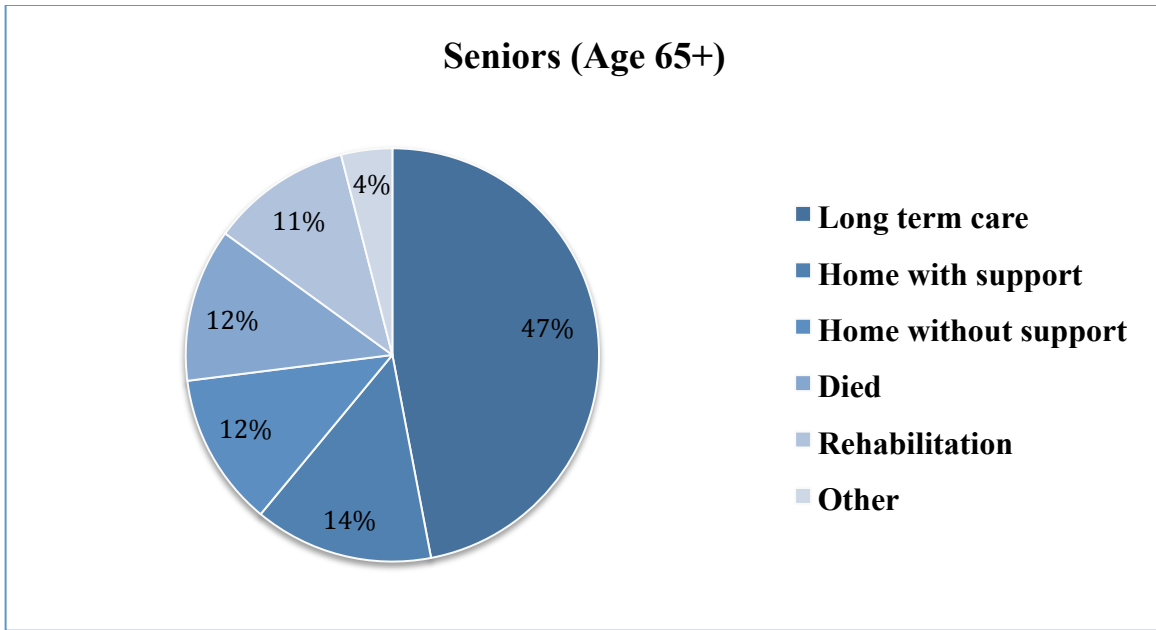

**Figure 2.2:** Seniors discharge destinations, ALC, Canada, 2009-2010 [35]

### 2.7.2. ALC in Atlantic Canada

In Atlantic Canada, during 2009–2010, 9254 ALC cases were discharged from hospitals (represented 4% of all patients discharged from hospitals). About 88% of ALC patients were 60 and older, with the majority (52%) being 80 and older. Also, 59% of ALC patients discharged were female (41% were male). Furthermore, 67% of ALC patients entered the hospital via the emergency department, while 31% were admitted via direct entry (admission to hospital via the facility’s admitting department). Approximately 49% of all patients discharged had 1 to 14 ALC days, and 16% had 61 to 180 ALC days [17, 35].

### ALC Seniors’ Health Conditions in Atlantic Canada

The top five Case Mix Group + (CMGs) among all ALC patients discharged accounted for 27%. The common CMGs among patients with 61 to 180 ALC days were Awaiting Placement, Dementia, Convalescence, General Symptoms and Chronic Obstructive Pulmonary Disease (COPD), with 41.3%. While, common CMGs among

patients discharged with 1 to 14 ALC days were Awaiting Placement, Convalescence, Fixation/Repair Hip/Femur, COPD and Palliative Care [17].

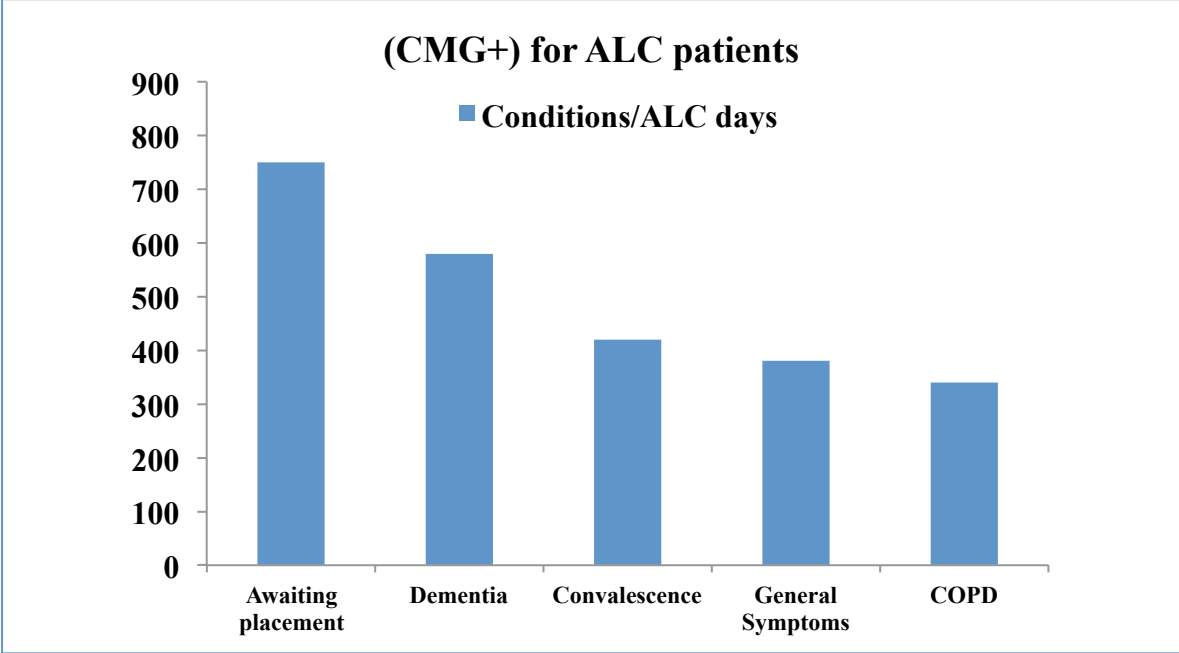
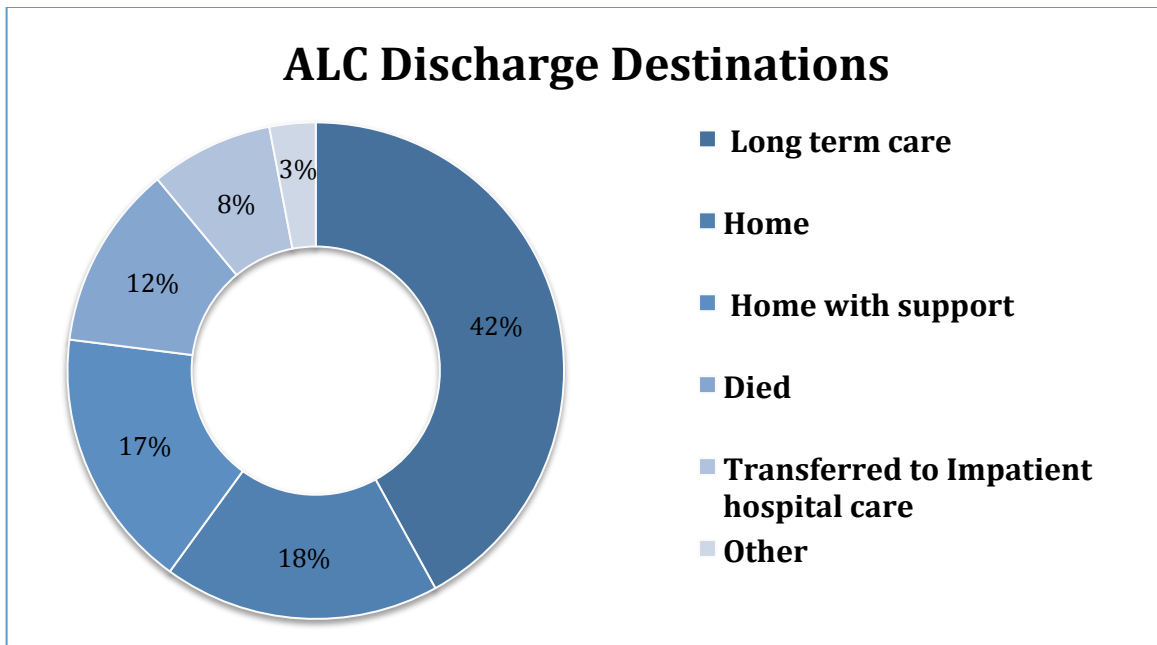

**Figure 2.3:** Highest CMG+ for patients discharged with ALC days, Atlantic Canada [17].

Source: Discharge Database 2009-2010, Canadian Institute of Health Information.

**ALC Discharge Destinations in Atlantic Canada**

Understanding ALC patients’ discharge destinations is important to specify and address any potential bottlenecks and patient flow throughout the health system. During 2009–2010, 42% of ALC patients in Atlantic Canada were discharged from hospital to long-term care facilities and 35% were discharged home with or without some form of support. Services and supports availability outside the hospital setting could affect if and how long patients remain in hospital after the acute care episode [17].



**Figure 2.4:** Discharge Destinations of ALC Patients, Atlantic Canada, 2009-2010 [17]

Source: Discharge Database, Canadian Institute of Health Information, 2009-2010

The figure below shows the ALC days distribution by discharge destination in each province, Canada:

Province	Total ALC Days	Discharge Distribution				
		Long Term Care	Home (with/without Support)	Died	Rehab	Other
NS	150.533	66	11	15	2	7
NB	113.096	65	17	13	3	2
PEI	8.955	76	9	12	0	4
NL	57.714	49	28	15	6	2

**Table 3.4:** ALC days distribution/discharge destination, Atlantic Canada 2008-2009 [37]

### ALC Costs in Atlantic Canada

Keeping patients in a hospital is more costly than any other care setting. Estimated daily costs of an ALC patient in Nova Scotia is about 500\$ [38]. Also, ALC patients

preoccupy acute care human resources. Approximately 50% of nurses and 60% of caregivers provide care to ALC patients [39]. Understanding costs associated with caring for an ALC patient in hospital is important when planning budgets and ensuring needed services. The average cost of a patient’s normal acute hospital stay in Atlantic Canada is represented below.

<b>Case Mix Group</b>	<b>Canada</b>	<b>N.B.</b>	<b>N.S.</b>	<b>N.L.</b>	<b>P.E.L.</b>
<b>Chronic Obstructive Pulmonary Disease</b>	6.208\$	5.571\$	5.943\$	5.644\$	6.133\$
<b>Dementia</b>	14.176\$	13.648\$	13.673\$	12.737\$	13.214\$
<b>Convalescence</b>	2.794\$	2.717\$	2.967\$	2.792\$	3.422\$
<b>Awaiting Placement</b>	7.710\$	7.318\$	9.246\$	7.473\$	7.031\$
<b>General Symptoms Signs</b>	5.935\$	5.932\$	5.666\$	4.957\$	4.841\$

**Table 2.5:** Average cost of patients’ acute hospital stay, Atlantic Canada, 2009-2010 [17]

Source: Patient Cost Estimator, Canadian Institute of Health Information

### **ALC Waiting Time, Length of Stay in Atlantic Canada**

According to the Canadian Institute of Health Information (2010), the waiting time associated with ALC patient in Atlantic Canada, ranges from: 1-365 days {{1-14}, {15-30}, {31-60}, {61-180}, {181-365}, {>366}}. In Nova Scotia, waiting times for a LTC bed still increasing, especially in the last years.

The table below represents the different waiting times to access a LTC bed, and the different ALC waiting days in the different health districts (DHAs) around Nova Scotia.

<b>Health District</b>	<b>Total Number of Beds</b>	<b>Waiting Time for a Nursing Home/ days</b>	<b>Waiting Time for a Residential Care Facility/ days</b>
<b>Capital Health</b>	2,545	186	156
<b>Cape Breton</b>	1,286	396	193
<b>Annapolis Valley</b>	764	106	41
<b>South West</b>	624	61	25
<b>Colchester East Hants</b>	622	162	54
<b>South Shore</b>	595	104	20
<b>Pictou County</b>	507	161	99
<b>Guysborough Antigonish</b>	460	212	86
<b>Cumberland</b>	418	131	13
<b>Number of ALC days in NS / Year</b>		2009-2010	2010-2011
<b>From Hospital</b>		80 days	65 days
<b>From the community</b>		110 days	150 days

**Table 2.6:** Average waiting days for LTC, ALC in Nova Scotia [10, 30, 37]

The **average** wait times measured from the date the client assessment is completed until the date the client accepts the offer. These dates represent the wait from the perspective of the client.

### **2.7.3 ALC Challenge**

As mentioned before, many seniors who don't really need acute care occupy a large number of hospital beds. This means that ALC patients do not receive the appropriate services while patients in need acute care are forced to wait. This leads to canceled surgeries and overcrowding in emergency departments. It is also known that waiting in hospital for post acute care prolongs patients' exposure to an environment that experience many avoidable adverse effects each year [35]. Moreover, it was proven that prolonged stays in the hospital and delayed discharges could also lead to deleterious effects on the ALC patient's health and are associated with serious adverse outcomes for seniors. These



include functional decline, pressure ulcers, and infections [3,36]. ALC patients have a 12% death rate while waiting [40]. They experience increased functional impairment and complex health needs in comparison to a LTC facility patient [39]. Thus, they require either additional acute care or premature discharge to LTC [35, 40]. For all these reasons, it is highly desirable for a health system to determine the necessary capacity for LTC services in order to prevent insufficient LTC capacity causing ALC congestion.

# Chapter 3

## Queuing Theory

---

### 3.1. Theoretical Foundation of Queuing Models

A.K. Erlang, a Danish engineer, published his first paper on queuing theory in 1909. In 1951, the term “queuing system” appeared in the article of D.G. Kendall. In 1953, Kendall published a paper on queuing notation. D.R. Cox proposed analysis of non-markovian process in 1955. In 1957, Jackson had considered an open queuing network with exponential servers and a poisson process. In 1958, F. Haight introduced parallel queues. In 1961, J. Little introduced little formula. In 1963-1967, Jackson presented closed queuing networks with exponential servers, and W.J. Gordon & G.F. Newell introduced them. In 1968, M. Mandelbaum and B. Avi-Itzhak introduced the concept of Fork-Join systems. In 1975, multi-class queuing networks occurred, especially BCMP networks, created by F. Baskett, K.M. Chandy, R.R. Muntz and F.G. Palacios. A special case is the network presented by F.P. Kelly, in which jobs belong to different classes, each class has a Poisson arrival process and a fixed route through the network. In 1977, P. J. Courtois introduced decomposition method. In recent years the progress of queuing theory use is noticed [41].

#### 3.1.1. Definitions & Structure

##### *Queuing theory & Queues*

Queuing theory is a mathematical approach to the analysis of waiting lines. Waiting lines (queues) are a part of everyday life. We all wait in queues to buy a movie ticket, obtain food in a cafeteria, start a ride in an amusement park, go to a doctor’s office visit...etc. We

become used to considerable amounts of waiting, but unusual long waits annoys us [42]. In health care, waiting lines can be found where patients arrive randomly for services and wait, such as walk-in patients and emergency rooms. Patients who arrive to health care services with appointments and wait to see their health care provider are not considered as waiting lines [43].

**The Basic Queuing Structure**

The basic process assumed by most queuing models is the following. *Customers (clients/patients)* requiring service are generated over time by an *input source*. These customers enter the *queuing system* and join a *queue*. At certain times, a member of the queue is selected for service by some rule known as the *queue discipline*. The required service is then performed for the customer by the *service mechanism*, after which the customer leaves the queuing system [42]. This process is depicted below:

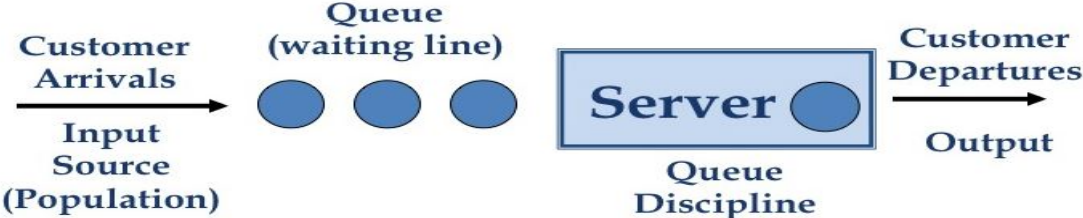

**Figure 3.1:** The basic queening system [42]

**3.1.2. Queuing System Characteristics**

Choosing a specific type of Model depends on the characteristics of the system under investigation. The main queuing model characteristics are: 1) the population source; 2) number of servers; 3) arrival patterns and service patterns; and 4) queue discipline.

### 3.1.2.1. Input Source (Population Source)

The *size* is the total number of customers that might require service. The population, which arrivals come from, is referred to as the **calling population** [42]. When analyzing a queuing problem, the first characteristic to look at is if the potential number of patients (the size) is limited or unlimited (finite or infinite). In a situation where the input **source is infinite**, patient arrivals, service (access) are unrestricted, and can greatly exceed system capacity at any time. A **finite source** situation exists when potential patients are limited to small numbers [43].

### 3.1.2.2. Number of Servers

The capacity of a queuing system is determined by the number and the capacity of its servers (a **line** or **channel**). Health care systems can be conceptualized as **single-line** or **multiple-line**, consist of **one** or **many phases** (steps in a queuing system), and may have **single** or **multi-queues**.

### 3.1.2.3. Types of Queuing Systems

There are four basic types of queuing systems and different combinations of the same can be used for very complex networks [43, 44].

**Single Queue – Single Channel – Single Phase System:** In which there is a single queue of customers waiting for service and only one phase of service is involved. Single-line systems in health care facilities are rare. For example: A flu inoculation clinic in which a single health care provider carries out both administration (paperwork, fee collection) and clinical care (inoculation) as a single server.

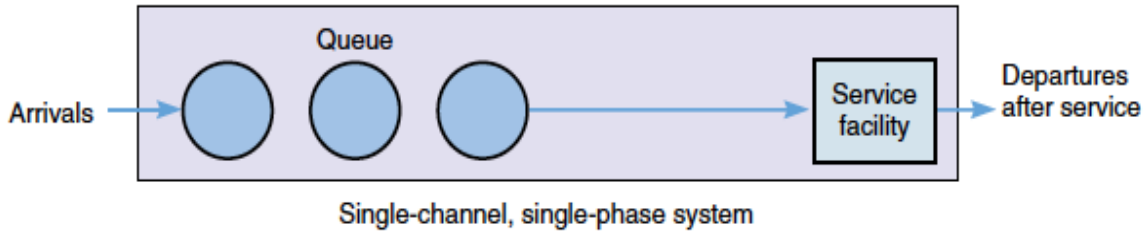

**Figure 3.2:** Single queue, single channel, single phase system

**Single Queue – Single Channel – Multiple Phase System:** In this case there's a single queue but the service involves multiple phases. Patients arrive at the registration counter, registered and then wait in a queue to be seen by a physician. There is queue formation or waiting time involved at each phase of the system. For example, many solo health care providers (physicians, dentists, therapists) have offices with receptionists and nurses.

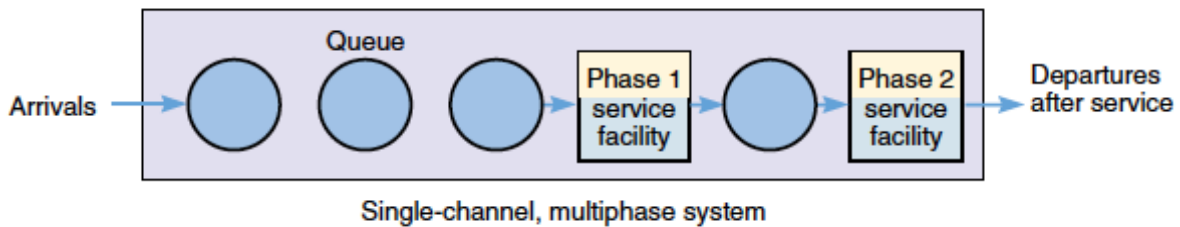

**Figure 3.3:** Single queue, single channel, multiple phase system

**Single Queue – Multiple Channels – Single Phase System:** In which patients form multiple queues, wait for a one-phase service. Patients also have the liberty to switch from one line to the other. Multiple-line systems are found in many health care facilities: hospitals, outpatient clinics, emergency services, and pharmacy store. Multiple-line queue systems can be either single-phase or multiphase. A single-phase, multiple-line system would be illustrated by an extension of flu inoculation to more than one server (many nurses giving inoculations and patients forming a single queue to wait).

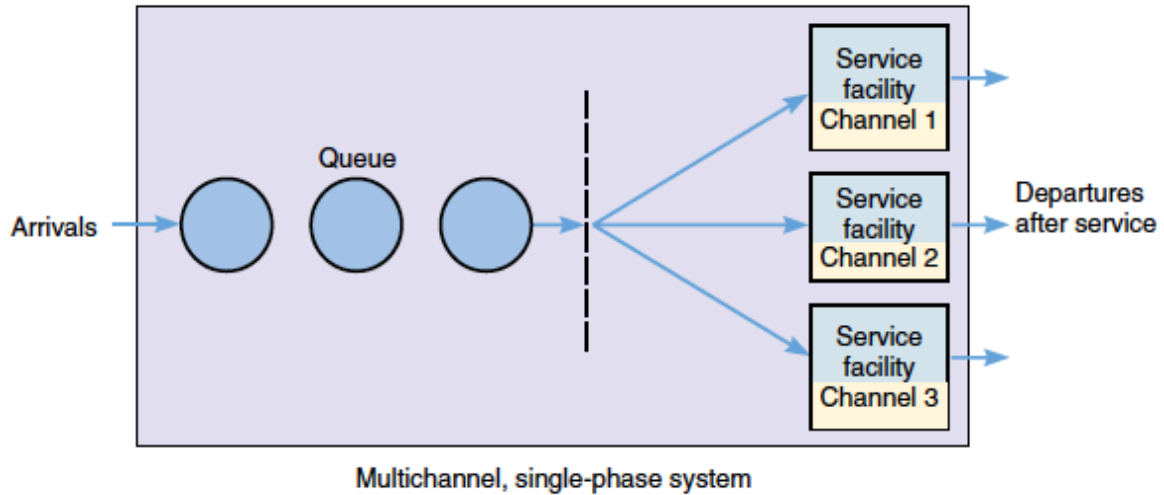

**Figure 3.4:** Single queue, multiple channels, single phase system

**Single Queue – Multiple Channels–Multiple Phase System:** This type of system has numerous queues and a complex network of multiple phases of services involved. This type of service is typically seen in a hospital setting, ER, multi-specialty outpatient clinics. For example in a hospital outpatient clinic, patient first forms the queue for registration, get triaged for assessment, get diagnostics, treatment, intervention or prescription and finally exits from the system or triage to different provider.

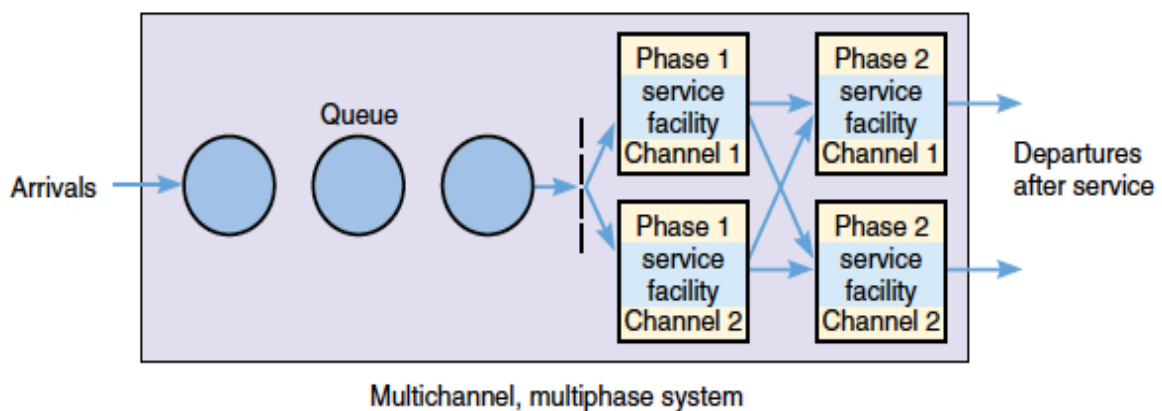

**Figure 3.5:** Single queue, multiple channels, multiple phase system

**Multiple Queues – Single Channel – Single Phase System:**

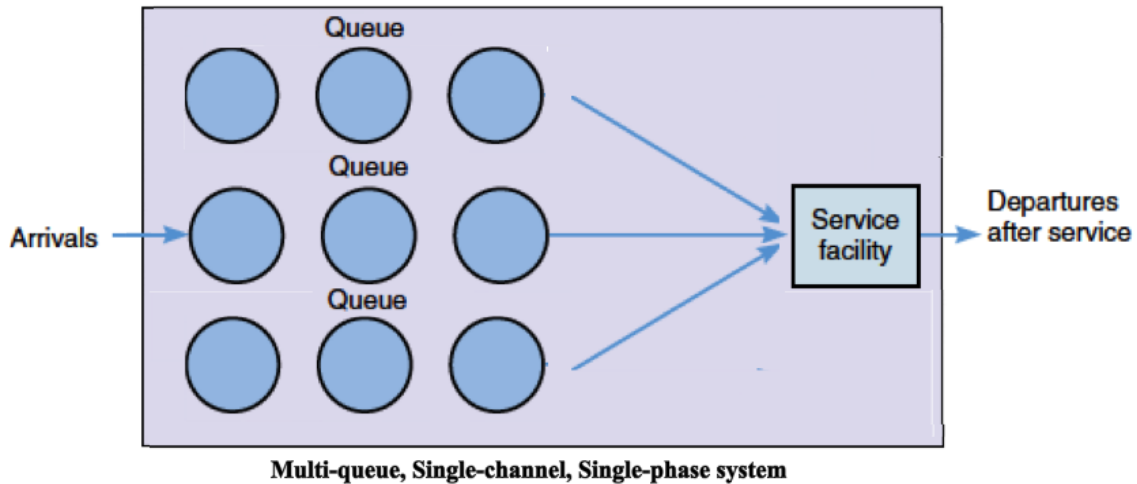

**Figure 3.6:** Multiple queue, single channel, single phase system

**Multiple Queues – Single Channels – Multiple Phase System:**

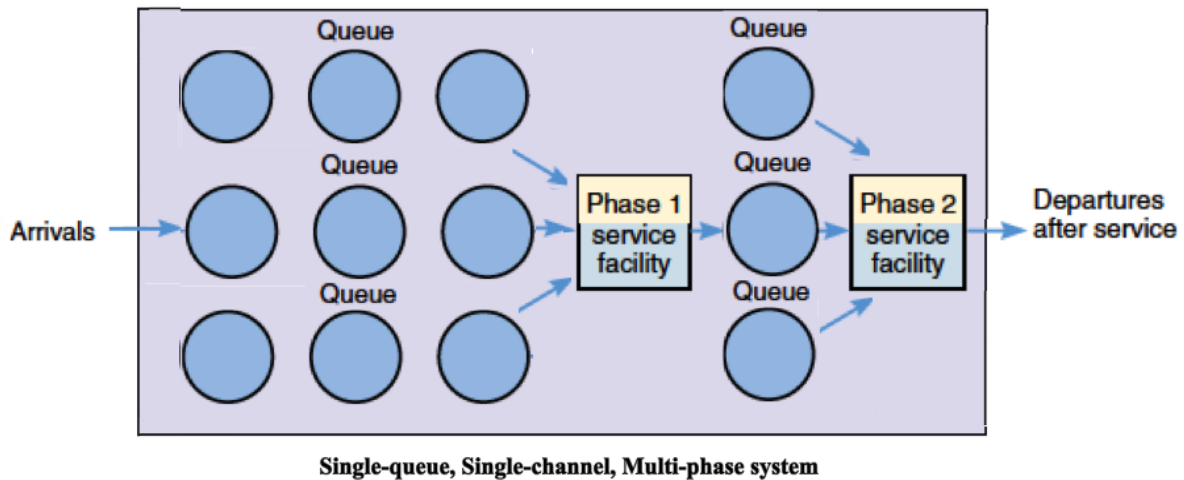

**Figure 3.7:** Multiple queue, single channel, multiple phase system

**Multiple Queues – Multiple Channels – Single Phase System:**

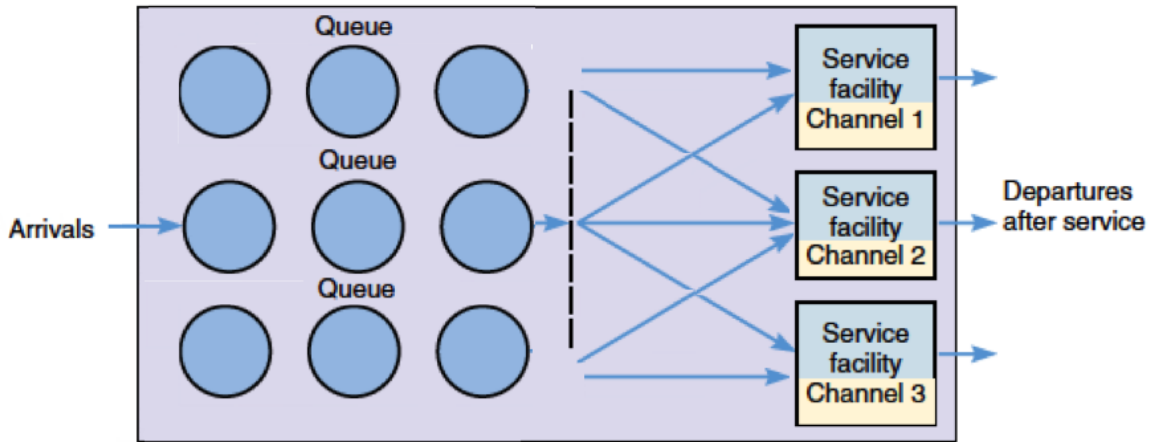

**Multi-queue, Multi-channel, Single-phase system**

**Figure 3.8:** Multiple queue, multiple channels, single phase system

**Multiple Queues – Multiple Channels – Multiple Phase System:**

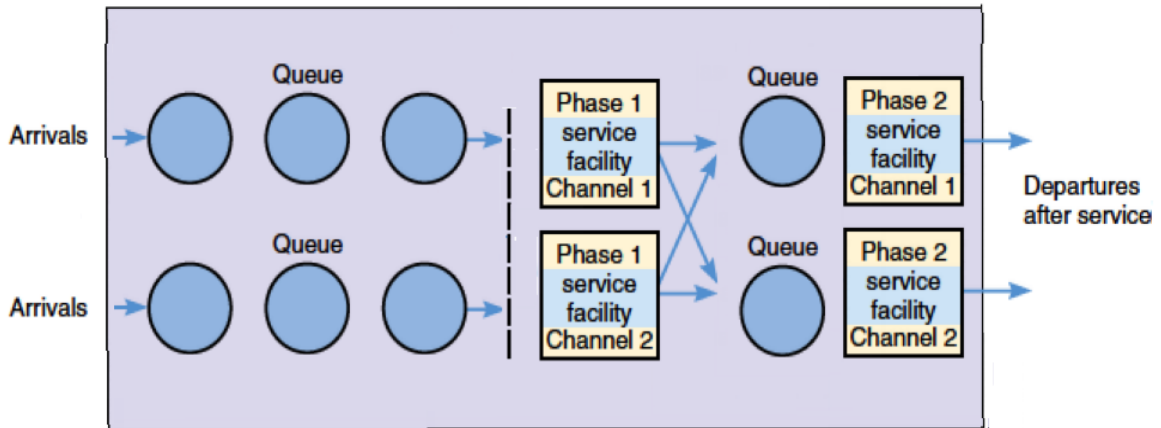

**Multi-queue, Multi-channel, Multi-phase system**

**Figure 3.9:** Multiple queue, multiple channels, multiple phase system



### Arbitrary Topology of Queues:

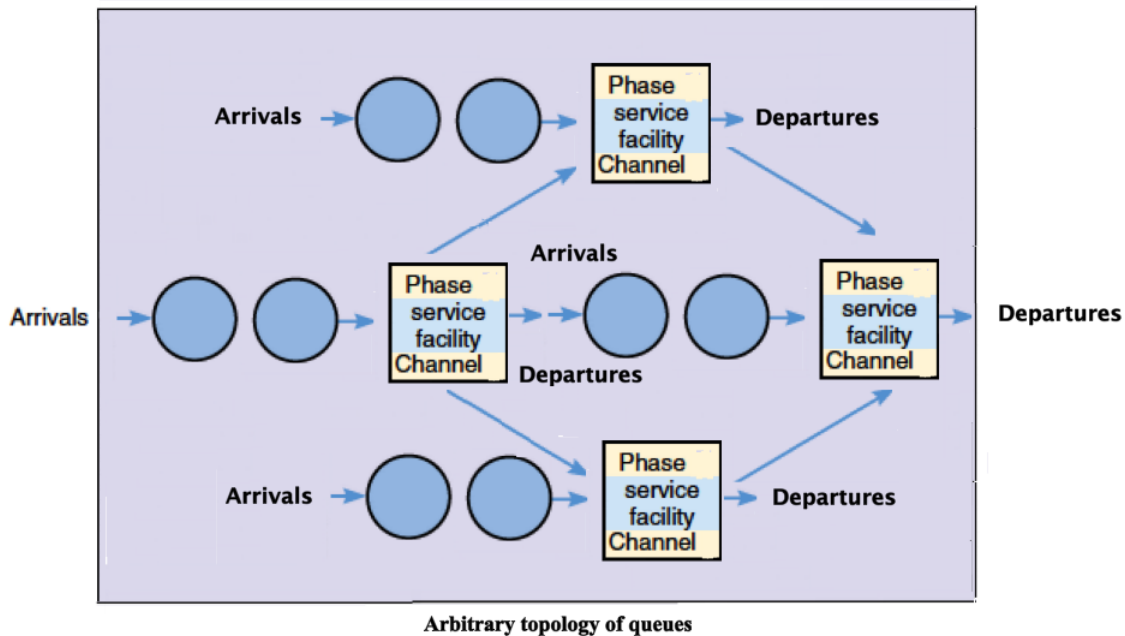

**Figure3.10:** Arbitrary topology of queues

#### **3.1.2.4. Arrival Pattern**

Random arrival and service patterns cause systems to be temporarily overloaded. Thus, waiting lines occur. The arrival patterns might be different on mornings, afternoons, evenings, months, years, and after working hours. The random nature of the arrivals, their numbers and the times between the arrivals, has to be measured. The variability can often be described by theoretical distributions. The most commonly used models assume that the patient arrival rate can be described by a Poisson distribution, and that the time between arrivals (inter-arrival time) can be described by a negative exponential distribution [43].

### 3.1.2.5. Service Pattern

Because of the varying nature of illnesses and patient conditions, the time required for clinical attention (service times) varies from patient to patient. For example: If a lab processes 10 customers per hour (rate), the average service time is six minutes. If the arrival rate is 12 per hour, then the average time between arrivals is five minutes. Thus, the Poisson distribution describes service and arrival rates, and inter-arrival times and service times are described by a negative exponential distribution [43].

### 3.1.2.6. Queue Discipline

Refers to the order in which customers are processed. First-come, first-served (FCFS, FIFO) basis is the most common rule and has special adaptations in health care queue discipline: shortest processing time first (simple surgeries scheduled first (operating room)); reservation first (physician office); critical first (emergency room). Other used disciplines are: Last-come first-served (LCFS, LIFO), serving in random order (SIRO), short processing time (SPT), and by priority (PR). For example: in the ER, FCFS basis is not used. Patients do not represent the same risk (or waiting costs); those with the highest risk (the most seriously ill) are processed first under a triage system, even though other patients may have arrived earlier [43].

### 3.1.2.7. Queue Characteristics & Behaviour

In a hospital, where patients can wait only in a bed, the limited number of beds prevents a unit from accepting patients. When a queue capacity is limited this is called: **Blocking** [45]. A queue can be formed as a single or as separate lines for each server. In the second type, patients may jump from queue to queue to reach a service point, but often lose more time because of service variability, this behavior is called: **Jockeying** [45]. Patients

who arrive and see big lines may change their minds and not join the queue, but go elsewhere to obtain service; this is called: **Balking**. If they do join the queue and are dissatisfied with the waiting time, they may leave the queue, this is called: **Reneging** [43].

### 3.1.3. Notations of Queuing Models

#### *Queuing Model Classification: Kendall's Notation*

In queuing theory, a three-symbol notation, known as Kendall's notation ( $A/B/s$ ), is used to identify queuing models. A nomenclature of  $A/B/C/D/E$  is used to describe them by their characteristics. Details for each component are below:

---

A: Specification of arrival process, measured by inter-arrival time or arrival rate.

B: Specification of service process, measured by inter-service time or service rate.

M: Negative exponential or Poisson distribution (Markovian).

D: Degenerate distribution or Deterministic distribution (Constant times value).

E: Erlang distribution.

G: A General distribution with known mean and variance.

C: Specification of number of servers "s".

D: Specification of queue or the maximum numbers allowed in a queuing system.

E: Specification of customer population.

---

D and E components are not used unless there is a specific waiting room capacity or a limited population. Example: A physician office with waiting room capacity of 15, 5 physicians, and Poisson arrival and service rates is described by M/M/5/15 [42, 43].

## ***Terminology & Notation***

Unless otherwise noted, the standard terminology and notation will be used [42, 43]

State of system = number of customers in queuing system.

Queue length = number of customers waiting for service to begin.

= state of system – number of customers being served.

$N(t)$  = number of customers in queuing system at time  $t$  ( $t \geq 0$ ).

$P_n(t)$  = probability of exactly  $n$  customers in queuing system at time  $t$ .

$P_0(t)$  = probability of zero units in system at time  $t$ .

$s$  = number of servers (channels) in queuing system.

$\lambda$  = arrival rate

$\lambda_n$  = mean arrival rate (expected number of new arrivals per unit time) when  $n$  customers are in system.

$\mu$  = service rate

$\mu_n$  = mean service rate (expected number of customers completing service per unit time) when  $n$  customers are in system.

$L_q$  = average number of customers waiting for service

$L_s$  = average number of customers being served

$L$  = average number of customers in the system (waiting or being served)

$W_q$  = average time customers wait in line

$W_s$  = average time customers spend being served (service time)

$W$  = average time customers spend in the system

$1/\mu$  = service time

$p$  = system utilization

### 3.1.4. Queuing Models

#### 3.1.4.1. Birth and Death Process Models (Exponential Distribution)

Most queuing models assume that the inputs (arriving customers) and outputs (leaving customers) of the queuing system occur according to the *birth-and-death process*. The term **birth** refers to the *arrival* of a new customer into the queuing system, and **death** refers to the *departure* of a served customer. The birth-and-death process describes *probabilistically* how  $N(t)$  changes as  $t$  increases. Broadly speaking, it says that *individual* births and deaths occur *randomly*, where their mean occurrence rates depend only upon the current state of the system. More precisely, the assumptions of the birth-and-death process are the following [42]:

**Assumption 1:** Given  $N(t) = n$ , the current probability distribution of the *remaining* time until the next *birth* (arrival) is *exponential* with parameter  $\lambda_n$  ( $n = 0, 1, 2, \dots$ ).

**Assumption 2:** Given  $N(t) = n$ , the current probability distribution of the *remaining* time until the next *death* (service completion) is *exponential* with parameter  $\mu_n$  ( $n = 1, 2, \dots$ ).

**Assumption 3:** The random variable of assumption 1 and the random variable of assumption 2 are mutually independent. The next transition in the state of the process is either  $n = n + 1$  (a single birth) or  $n = n - 1$  (a single death), depending on whether the former or latter random variable is smaller.

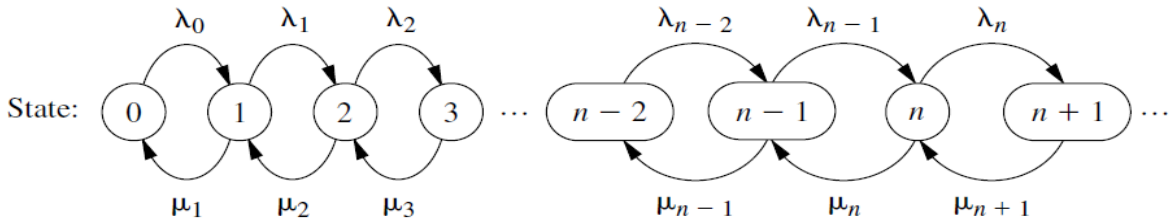

**Figure 3.11:** Rate diagram for the birth and death process [42]

The values of the  $\lambda_n$  will be the same for all values of  $n$ , and the  $\mu_n$  also will be the same for all  $n$  except for such small  $n$  ( $n = 0$ ) that a server is idle. However, the  $\lambda_n$  and the  $\mu_n$  also can vary with  $n$  for some queuing systems. For example, one of the ways in which  $\lambda_n$  can be different for different values of  $n$  is if potential arriving customers become increasingly likely to *balk* (refuse to enter the system) as  $n$  increases. Similarly,  $\mu_n$  can be different for different  $n$  because customers in the queue become increasingly likely to *renege* (leave without being served) as the queue size increases. Most models in queuing theory are based directly upon the Birth-and-death process. These models have a **Poisson input** and **exponential service times**. The models differ only in their assumptions about how the  $\lambda_n$  and  $\mu_n$  change with  $n$ . Here are three types of these queuing systems models:

**Models with Infinite Queue (Waiting Room): M/M/s Model**

The *M/M/s* model assumes that: all *inter-arrival times and service times* are independently and identically distributed according to an exponential distribution, and that the number of servers is  $s$  (positive integer). Thus, this model is just the special case of the birth-and-death process where the queuing system's *mean arrival rate* and *mean service rate per busy server* are constant ( $\lambda$  and  $\mu$ , respectively) regardless of the state of the system.

When the system has just a *single server* ( $s = 1$ ), the implication is that the parameters for the birth-and-death process are  $\lambda_n = \lambda$  ( $n = 0, 1, 2, \dots$ ) and  $\mu_n = \mu$  ( $n = 1, 2, \dots$ ).

When the system has *multiple servers* ( $s > 1$ ) and the mean service rate per busy server is  $\mu$ , the overall mean rate of service completions for  $n$  busy servers must be  $n\mu$ . Therefore,  $\mu_n = n\mu$ , when  $n \leq s$ , whereas  $\mu_n = s\mu$ , when  $n \geq s$ , so that all  $s$  servers are busy [42].



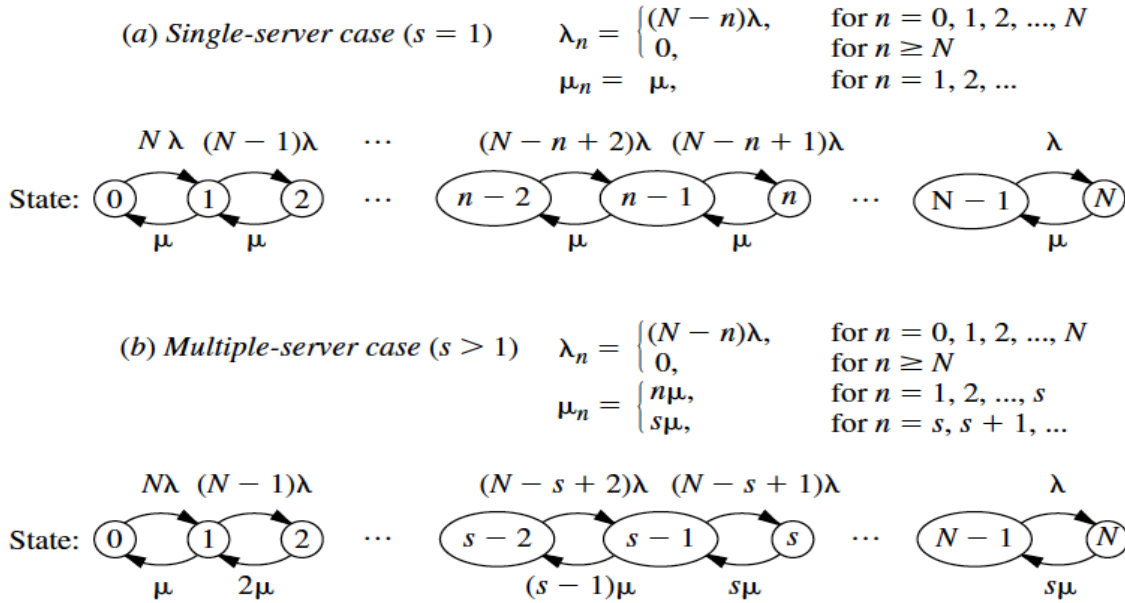

**Figure 3.13:** Rate diagrams for the finite  $M/M/s$  model [42].

**Models with Finite Queue (Waiting Room):  $M/M/s/K$  Model**

Queuing systems sometimes have a finite queue; the number of customers in the system is not permitted to exceed some specified number (denoted by  $K$ ), so the queue capacity is  $K - s$ . Any customer that arrives while the queue is “full” is refused entry into the system and so leaves forever. From the viewpoint of the birth-and-death process, the mean input rate into the system:  $\lambda_n = \lambda$  ( $n = 0, 1, 2, \dots, K - 1$ ) and  $\lambda_n = 0$  ( $n \geq K$ ). Because  $\lambda_n = 0$  for some values of  $n$ , a queuing system that fits this model always will eventually reach a steady-state condition, even when  $\rho = \lambda/s\mu \geq 1$ . This model commonly is labeled  $M/M/s/K$ , where the presence of the fourth symbol distinguishes it from the  $M/M/s$  model. The single difference between the two models is that  $K$  is finite for the  $M/M/s/K$  model and  $K = \infty$ , for the  $M/M/s$  model.



### 3.1.4.2. Models with Non-Exponential Distribution

Most of the queuing theory models in the previous section are based on the birth-and-death process. Their inter-arrival and service times are required to have exponential distributions. The assumption is a reasonable approximation in many situations but not when the arrivals are carefully scheduled or regulated. Also, the service-time distribution frequently deviates from the exponential form when the service requirements are quite similar. Thus, it is important to have other queuing models that use alternative distributions.

#### Models with Infinite Queue

##### *Models with Poisson Input: M/G/s, M/D/s, M/E<sub>k</sub>/s Models*

The M/G/s model assumes that the queuing system has:  $s$  servers and a *Poisson input process* with a *fixed* mean arrival rate  $\lambda$ . It is assumed that the patients have independent service times with the same probability distribution; no restrictions are imposed on what the service-time distribution can be. It is only necessary to estimate the mean  $1/\mu$  and variance  $\sigma^2$  of this distribution. The M/D/s model often provides a reasonable representation for the situation where the service consists of essentially the same routine task for all patients, because it assumes that all service times actually equal some fixed constant (*Degenerate service-time distribution*) and that we have a Poisson input process with a fixed mean arrival rate  $\lambda$ . The M/D/s model assumes *zero variation* in the service times ( $\sigma = 0$ ), whereas the exponential service-time distribution assumes a *very large variation* ( $\sigma = 1/\mu$ ). Between these two rather extreme cases lies a long middle ground ( $0 < \sigma < 1/\mu$ ), where most actual service-time distributions fall. Another kind of theoretical service-time distribution that fills this middle ground is the *Erlang distribution* (named after the founder of queuing theory).

### ***Models with Poisson Output: GI/M/s, D/M/s, E<sub>k</sub>/M/s Models***

The assumption of Poisson input process (exponential inter-arrival times) is violated if the arrivals are scheduled or regulated in some way that prevents them from occurring randomly. The service times have an exponential distribution with a fixed parameter; three such models are available [42, 46]. The first new model (GI/M/s) imposes no restriction on what the inter-arrival time distribution can be. The second new model (D/M/s) assumes that all inter-arrival times equal some fixed constant, which would represent a queuing system where arrivals are scheduled at regular intervals. The third new model (E<sub>k</sub>/M/s) assumes an Erlang inter-arrival time distribution, which provides a middle ground between regularly scheduled (constant) and completely random (exponential) arrivals.

### ***Models without a Poisson Input/ Output: E<sub>m</sub>/E<sub>k</sub>/s, E<sub>k</sub>/D/s, D/E<sub>k</sub>/s, GI/G/s Models***

If neither the inter-arrival times nor the service times for a queuing system have an exponential distribution, then there are four additional queuing models. One of these models (E<sub>m</sub>/E<sub>k</sub>/s) assumes an Erlang distribution for both these times. Other two models (E<sub>k</sub>/D/s and D/E<sub>k</sub>/s) assume that one of these times has an Erlang distribution and the other time equals some fixed constant. Also, there is the GI/G/s model that requires the fewest assumptions about the shape of inter-arrival and service time.

### **Models with Finite Queue: M/G/s/K, GI/G/s/K Models**

The M/G/s/K model assumes that the queuing system has a: *s server* and a *Poisson input process* (exponential inter-arrival times) with a *fixed* mean arrival rate  $\lambda$ . The service times impose a general distribution. The GI/G/s/K model assumes that both service and inter-arrival time distributions impose no restrictions (general distribution). Thus, it makes

it more difficult to analyze, except when inter-arrival and service time distributions have some specific forms.

### **3.1.4.3. Priority Models**

In priority queuing models, the queue discipline is based on a priority system; the served queue members are selected based on their assigned priorities. Very sick patients are usually given priority to be taken care of. Thus, the use of priority-discipline models often provides a very welcome refinement over the more usual queuing models [42, 46]. We present two models that assume there are  $N$  priority classes (class 1 has the highest priority, class  $N$  has the lowest). When a server becomes free, customers are served in the order of their priority, but on a FCFS basis within each priority class. A Poisson input process and exponential service times are assumed for each priority class. However, the models do permit the mean arrival rate to differ among priority classes. It is also assumed that the expected service time is the same for all priority classes. The distinction between models is whether the priorities are non-preemptive or preemptive.

The first model assumes non-preemptive priorities: If a higher-priority customer enters the system; a customer being served cannot be ejected back into the queue and must be served without interruption. The second model assumes preemptive priorities: If a higher-priority customer enters the system; the lowest-priority customer being served is ejected back into the queue. A server will begin serving the new arrival immediately. When a server finishes a service, the next customer receiving service is selected with the same discipline. Thus, a preempted customer will be served after many tries.

The two models actually are identical to the  $M/M/s$  model, except for the order in which customers are served. For both models, the distinction between customers in different

priority classes is ignored; all customers would arrive according to a Poisson input process and have the same exponential distribution for service time customers. In a priority model, this distribution has a larger variance, because the waiting times in the highest priority classes tend to be smaller than those under a first-come-first-served discipline. Also, the waiting times in the lowest priority classes tend to be larger. The total number of customers in the system tends to be weighted toward the lower-priority classes; and it is just the reason for using priorities on the queuing system in the first place [42].

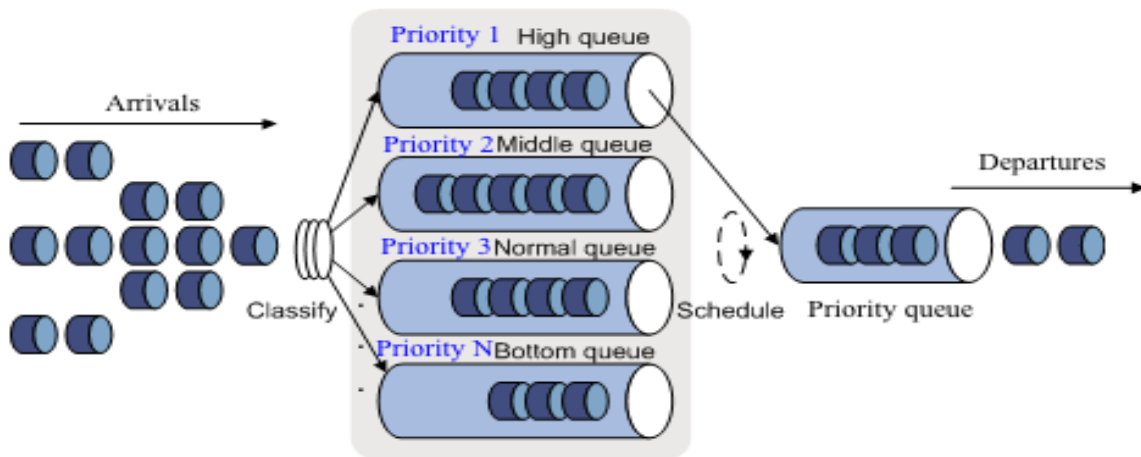

**Figure 3.14:** Priority queuing system

#### 3.1.4.4. Fork-Join Models

The model of Fork-Join systems can be applied to parallel analysis [2, 44]. The job arriving to a fork-join queue splits (at the fork point) into  $N$  independent tasks that are simultaneously assigned to  $N$  servers. Each task requires a serve. At each server tasks can belong to the different jobs. When a task completes execution, it will wait at the join queue until all its sibling tasks are served. A join merges several tasks into a single job. A job is completed and departs the parallel resource after all of its tasks complete execution [47].

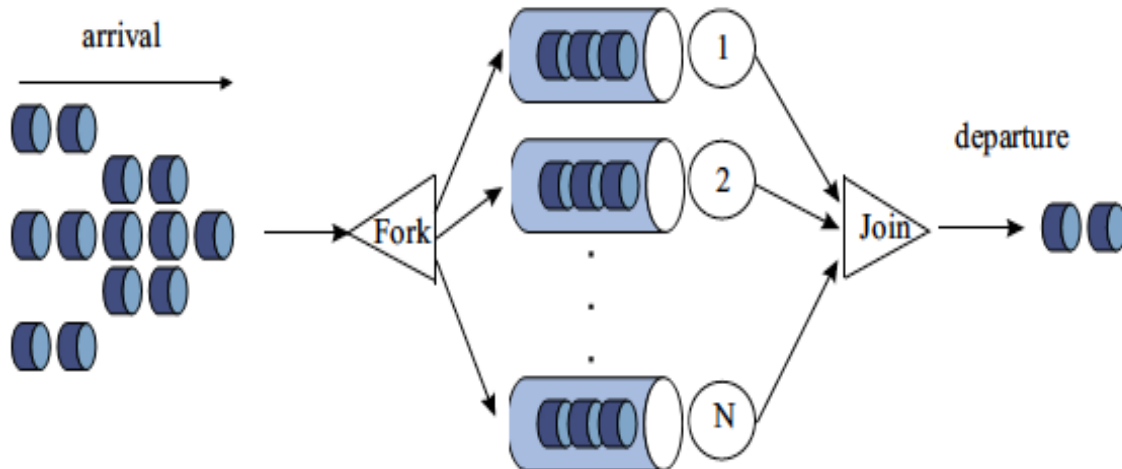

**Figure 3.15:** Fork-join queuing system

### 3.1.5. Queuing Networks

Queuing systems encountered in OR studies are sometimes actually networks of service facilities where customers must receive service at some of or all these facilities. Hospitals and specialized treatment facilities for particular medical conditions (cancer, cardiovascular, or neurological services) perform a range of services, each with its own resources (servers) and queues. Such facilities are best modeled as networks of queues.

#### 3.1.5.1. System of Infinite Queues

*Systems of infinite queues* suppose that all customers must receive service at a series of  $m$  service facilities in a fixed sequence and that each facility has an infinite queue, so that the series of facilities form a system of infinite queues in series. Also, each service facility has a Poisson input with parameter  $\lambda$  (the M/M/s model), and that each facility  $i$  ( $i = 1, 2, \dots, m$ ) has an exponential service-time distribution with parameter  $\mu_i$  for its  $s_i$  servers, where  $s_i \mu_i > \lambda$  (the equivalence property). Thus, the elementary M/M/s model can be used to analyze each service facility independently of the others. The probability of having  $n$  customers at a given facility is the product of the individual probabilities of  $n_1$  customers at facility 1,  $n_2$

customers at facility 2, . . . Similarly, the expected total waiting time and the expected number of customers in the entire system can be obtained by merely summing the corresponding quantities obtained at the respective facilities. Unfortunately, the equivalence property and its implications do not hold for the case of *finite queues in series systems*. This case is important in practice, because usually in service facilities queues have a limitation. For such systems, no simple product form solution is available.

### 3.1.5.2. Jackson's Networks

*Jackson networks* are another prominent type of networks where the M/M/s model can be used to analyze each service facility independently. The characteristics of a Jackson network are the same as assumed above for the system of infinite queues in series, except now the customers visit the facilities in different orders (and may not visit them all). For each facility, its arriving customers come from both outside the system (according to a Poisson process) and the other facilities. These characteristics are summarized as: A Jackson network system of  $m$  service facilities where facility  $i$  ( $i = 1, 2, \dots, m$ ) has:

1. An infinite queue
2. Customers arrival from outside follow a Poisson input process with parameter  $a_i$
3.  $s_i$  servers with an exponential service-time distribution with parameter  $\mu_i$

A customer leaving facility  $i$  is routed next to facility  $j$  ( $j = 1, 2, \dots, m$ ) with probability:  $p_{ij}$  or departs the system with probability:  $q_i = 1 - \sum p_{ij}$ , ( $j = 1, 2, \dots, m$ ),  $i$  is different than  $j$

Any such network has the following key property: Under steady-state conditions, each facility  $j$  ( $j = 1, 2, \dots, m$ ) in a Jackson network behaves as if it were an independent M/M/s queuing system, arrival rate:  $\lambda_j = a_j + \sum \lambda_i p_{ij}$ , where: ( $i = 1, 2, \dots, m$ ) and  $s_j \mu_j > \lambda_j$  [42, 47].

### **3.1.5.3. Gordon-Newell Networks**

These networks, also known as closed Jackson's networks, fulfill the assumptions of Jackson's networks, except one: customer can neither enter nor leave the network. A fixed number of jobs always circulate in this type of queuing network [47, 48].

### **3.1.5.4. Kelly's Network**

Another case of queuing networks is the network of Kelly with different classes of customers. Each type has a Poisson arrival process and a fixed route in the network. Customers served at each system have exponential service time distribution. Each system may serve several different customer classes. All systems have infinite capacity [48].

### **3.1.5.5. The BCMP Networks**

The BCMP queuing network is a multi-class network discussed by Baskett, Chandy, Muntz and Palacios. These networks include different class of jobs, different queuing discipline and generally distributed service times. Routes in the network may depend on the job type and the customer can change his class while passing in the network [47, 48].

## **3.2. Queuing Theory in Healthcare**

Organizations that provide Health care processes can be viewed as Queuing systems in which the patients arrive, wait for the service, obtain service and then depart. The resources (or servers) in these queuing systems are the trained personnel and specialized equipment required to serve patients [49]. Queuing theory use in healthcare essentially deals with patient flow through the system. Queuing is minimized when patient flow is good. If the flow is bad, patients may suffer considerable queuing delays and then the system may suffer loss of business. Delays can be reduced through the following ways [44, 50]:

- Synchronization of work among service stages (Example: coordination of tests, treatments, discharge processes)
- Scheduling of resources to match patterns of arrival (Example: doctors, nurses and equipment)
- Constant system monitoring (Example: tracking number of waiting patients by location, diagnostic grouping and acuity) linked to immediate actions.

### 3.2.1. Queuing Theory Applications in Healthcare

Queuing theory is now extensively used in the following healthcare settings: emergency room, walk in patients and outpatient clinics, for facilities and resource planning, for emergency and disaster management preparedness, ...etc. [44, 50].

#### 3.2.1.1. Emergency Room Arrivals

This is one of the areas where most of the research of queuing theory has been done. Many patients leave the ED (Emergency Departments) to seek services at a different place because of the crowded queues and prolonged waiting times. This is all a result of many ED closure and significant variation in ED patient arrival rates.

Queuing theory application major goal in such area is analyzing arrival patterns of the patients over time to a particular ED or an area (city, state, and nation), and using those results for facilities design and appropriate staffing.

#### 3.2.1.2. Walk in Physician Offices & Hospitals Clinics

Most queuing models studies on the management of healthcare clinics have common objectives that included: reducing patient's time in the system (outpatient clinic), customer service improvement, better resource utilization, and operating costs reduction. Such cases



analysis involves investigation of: patient's arrival and flow, system structure and scheduling.

Moreover, queuing theory can be applied to hospital outpatient clinics and surgeries to determine the arrival patterns of patients and surgeons, or the service rate and surgeries schedule for better quality and efficiency. For example, interns or assisting staff members in a hospital perform small surgeries, and the experienced surgeons or a team performs the complicated ones. The interns start their work early, but the experienced surgeons arrive later during the day.

#### **3.2.1.3. Hospital Pharmacy & Pharmacy Stores**

In Pharmacy, Queuing theory applications are few. Queuing theory can be used to assess many factors such as prescription fill time, patient waiting time, patient counseling-time and staffing levels. Queuing theory application may be beneficial in pharmacies with high volume outpatient workloads and those with multiple points of service.

#### **3.2.1.4. Health Care Resource & Infrastructure Planning for Disaster Management**

Disasters cause significant human and economic damage and they all require a crisis response like: immediate rescue of people, provision of needed medical services and damage containment to people and property. In such scenarios, queuing models are usually used in conjunction with simulation to answer the “what-if” questions, to plan, organize and be prepared for the calamities. For Example, if H5N1 bird flu spreads in Canada and causes an epidemic, it would be colossal crisis situation. Policy makers and administrators will use queuing and simulation to give data on: how many people and what locations would be affected, disease spread speed, number and characteristics of healthcare workers needed, pharmaceutical supplies, vaccines, number of beds and so on.

### 3.2.1.5. Public Health

Queuing models can also be used for public health. For example, the resources needed for mass vaccination camp in a particular area, facility and resource planning for changing disease profiles or changing demographics.

### 3.2.2. Queuing Theory & Healthcare Capacity Planning

Why use the queuing theory in healthcare? The answer is that the goal of queuing analysis and its application in healthcare organizations is to “minimize costs” to the organization – both tangible and intangible. The costs that are considered can be divided into two broad categories [44, 50]:

**Waiting Costs:** Costs associated with patients having to wait for the service.

- Loss of business to HCO, as some patients might not be willing to wait for the service and may decide to go to the competing organizations.
- Costs incurred by society for example increased interventions and cost due to delay in care or the value of patients’ time.
- Decreased patient satisfaction and quality of care.

**Capacity Costs:** Costs of providing the service to patients.

- Salaries paid to employees or for waiting for service from other server, for example waiting for the pathology report, radiology report, labs, etc.
- Cost of waiting space, facilities, equipment, and supplies.

If the organization decides to increase the level of the service provided, the cost will increase, if it decides to limit the same, costs associated with waiting for the services would increase. So the manager has to balance the two costs and make a decision about the provision of optimum level of service [44].

### 3.2.3. Measures of Healthcare Queuing System Performance

The health care managers and policy makers analyze the results, identify the needs/gaps, carry out necessary interventions/modifications and evaluate the success/failure of existing or proposed service systems. They must consider five typical measures [44, 50]:

1. Average number of patients waiting (in queue or in the system).
2. Average time the patients wait (in queue or in the system).
3. Capacity utilization.
4. Costs of a given level of capacity.
5. Probability that an arriving patient will have to wait for service.

The system utilization measure reflects the extent to which the servers are busy rather than idle. It might seem that health care managers would seek 100 percent system utilization. However, increases in system utilization are achieved only at the expense of increases in both the length of the waiting line and the average waiting time. Under normal circumstances, 100 percent utilization may not be realistic; a health care manager should try to achieve a system that minimizes the sum of waiting costs and capacity costs. In queue modeling, the health care manager also must ensure that average arrival and service rates are stable, indicating that the system is in a steady state, a fundamental assumption [44, 50].

### 3.2.4. Queuing Models in Healthcare Literature

Here are few articles that present and focus only on a queuing model review, mathematical models or limit their scope to a single type of application: In [51] the authors review the use of queuing theory in pharmacy applications with particular attention to improving customer satisfaction. The research in [52] sums up a brief history of queuing theory use in healthcare, it points to an extensive bibliography of related research. However,

it provides no description of the applications or results. Moreover, [53] presents the theory of queuing as applied in healthcare. It discusses the relationship amongst delays, utilization and the number of servers; the basic M/M/s model, its assumptions and extensions; and the applications of the theory to determine the required number of servers

#### **3.2.4.1. Waiting Time & Utilization Analysis**

**Reneging:** The phenomenon of *reneging* is an important characteristic of healthcare systems. The probability that a patient reneges usually increases with the queue length and the patient's estimate of how long he must wait to be served. In [54], they calculate the percentage of patients who leave an emergency department without getting help using arrival rate, service rate, utilization, and capacity. From this percentage, they determine the resulting revenue loss. Also, [55] finds that in order to reduce the number of patients who leave an emergency department without being served, separating non-acute from acute patients and treating them in dedicated areas is a possible approach.

**Variable Arrival Rate:** Most analytical queuing models assume a constant arrival rate, but many healthcare systems have a variable arrival rate. In other cases, the arrival rate depends upon the state of the system. First, [56] proves that a system with congestion discourages arrivals. He suggests that decreasing service capacity has little effect on queue length because when patients realize that waiting times would reduce, the arrival rate increases, thus the queue increases again. Second, [57] presents an M/G/s model for service times of any fixed probability distribution and for arrival rates that decrease linearly with the queue length and the expected waiting time. Last, [58] shows how arrival rate may increase over time due to population growth or other factors. Also, he studies how an increase in

patient arrival rate affects waiting times and queue length for an emergency radiology service.

**Priority Queue Discipline:** In most healthcare settings, the queue is either FIFO or a priority discipline, unless an appointment system is in place. In [59], it is shown that it is possible, when utilization is high, to minimize waiting times by giving priority to clients who require shorter service times. Moreover, [60] studies patients' waiting times when primary care patients use the ER. A priority discipline for different categories of patients and a FIFO discipline for each category were proposed. They find that the priority discipline reduces the average wait time for all patients: but higher priority patients waiting time reduces, and lower priority patients waiting time increases. In addition, [61] investigates the effect of emergency requests on the waiting times of scheduled patients with deterministic processing times. It is a pre-emptive priority queuing system in which the emergency patients interrupt the scheduled patients and the latter's service is restarted as opposed to being resumed.

#### **3.2.4.2. System Design**

Limiting waiting time is important when designing a healthcare system because waiting is undesirable. This section reviews work on determining system capacity, resource allocation based on system goals and requirements. The variables of interest are usually staffing levels, beds, or other key resources. The paper [62] seeks the optimal staffing at a hospital-scheduling department that handles phone calls of variable intensity throughout the day. The paper redistributed staffing according to calls intensity periods. Thus, customer complaints reduced without an addition of staff.

**Blocking:** In systems with blocking, congestion not only increases patient waiting time but also reduces the throughput of the system. First, [63] determines the optimal number of beds in a cardiology department modeled as a network of 3 sub-departments. The research finds that too few beds downstream is the primary cause of refused admissions, and suggests that departments could be merged to meet the goal of higher occupancy rates. Second, [64] considers activating a second operating room (OR) team during the night shift. Using queuing theory, they find that the probability of two patients needing the OR services is negligible.

**Minimize Costs:** Minimizing costs by finding the resource allocation that costs the least or the most profit is important after designing a system using queuing theory. In [65], the researcher modeled a system where there is a holding cost associated with an empty bed, a penalty cost associated with each patient turned away, and a profit assigned to each day a bed is occupied. Proposed use backup beds (only staffed during peak demand) to reduce the probability of patient turn-away at a marginal cost. Also, [66] chooses staffing capacity in an outpatient radiology service with a limited waiting area. He suggests scheduling patients by clustering them based on expected examination duration.

#### **3.2.4.3. Appointment Systems**

Compared to systems without appointments, systems with appointments reduce the arrival variability and waiting times at the facility without increasing server idleness. They require patients to wait outside the facility; this waiting time can be productive and has low cost to the patient. In [67], the research seeks to design an appointment system to reduce the number of patients in the queue, and reduce patient's waiting time without significantly increasing doctor idle time. Furthermore, [68] points out that patient no-shows without

cancelling appointments could lead to waste of resources. They propose implementing short-notice appointment systems based on a queuing network analysis. These ideas did not improve the system because of the clinic using many visiting doctors and the patients being unable to schedule visits with their primary care physician.

**Bottlenecks:** In a queuing network, a patient may have to go through several nodes, and several queues to obtain the desired service. Some nodes where demand exceeds service become bottlenecks. Such bottlenecks have high utilization and increase overall waiting times while other nodes have low utilization. The research, in [69], finds the bottlenecks at the Hurtado Health Center appointment clinic by collecting data and analyzing it using queuing network analysis software program.

**System Size:** Presents results for systems of different scales where the size of healthcare organizations varies. First, [70] investigates the redistribution of hospital beds among the inpatient hospital departments. A baseline patient capacity is chosen and additional beds are then allocated for each department to minimize patient overflows between departments. Next, [71] investigates the hierarchy of burn care facilities where excess demand at one facility is absorbed by other facilities in the same region and overflows at one region are absorbed by other regions.

### 3.2.5. Alternative Level of Care & Long Term Care in Literature

ALC is an area within Nova Scotia's health care system that has not commonly been addressed in the literature. No studies could be found that address the process of a patient leaving from Acute Care/ALC facility to a LTC facility/Home Care. However, studies have looked at the characteristics of ALC patients. Another area of ALC patient research is ensuring proper facility placement after AC. The main goal of ALC discharge planning is to

ensure that patients receive appropriate support and services outside the hospital. Nevertheless, readmission occurs with 15% of ALC patients [40].

<b>Province</b>	<b>Readmitted to Hospital within 30 days of Discharge Home</b>
British Columbia	17%
Alberta	14%
Saskatchewan	18%
Ontario	17%
New Brunswick	18%
Nova Scotia	15%
Prince Edward Island	26%
Newfoundland & Labrador	15%

**Table 3.1:** % of ALC patients re-admitted within 30 days of discharge to home [37].

The paper [72] researched patient’s information from an orthopedic and stroke patient to determine their potential appropriate LTC facility between a nursing home, a rehabilitation center, or the patient's home. Similarly, [73] concluded that based on an acute stroke patient's functional status at admission, social support, gait status, and presence of medical complications it can be determined if the patient should go to a private home, rehabilitation center, or LTC facility. The studies discussed have determined how to ensure appropriate patient transfer after acute care, but have not explored if this has an effect on ALC days.

Other studies focused on post acute care and addressed the patient flow after discharging from acute care to other facilities such as LTC or home care. The main goals of such studies are how to predict the future demand and determine the optimal capacity of LTC facilities. In [74], the researcher developed a deterministic multistate Markov model for Home and Community Care in British Colombia. They incorporated publicly funded care, non-publically funded care, and home care. The model used the predicted changes in



both age demographics and the health status of elderly citizens as inputs to predict future demand. Next, [75] developed an optimal control system to determine the optimal capacity for publicly funded community based LTC facilities. They conclude that such facilities are less expensive than nursing home care in which providing housing for patients are costly. [76] used simulation model based on a Markov cycle tree structure to predict demand for different types of LTC in Portugal for the period of 2010-2015. Uncertainty was modeled through an approach that combines scenario analysis with probabilistic sensitivity. Moreover, [77] analyzed the impact of discharge rates on the number of post acute time in the hospital through a queuing model. Also, [78] used a queuing model with blocking to analyze the flow of patients out of acute care and into a series of mental health facilities. Furthermore, [79] provides a Markov Decision Process (MDP) model to determine the optimal policy for the placement of hospital patients into long-term care in order to maintain the hospital census of patients waiting for placement below a pre-determined threshold. In addition, [80,81] described an approach to set LTC capacity levels over a multiyear planning horizon in order to achieve target wait time service levels. They proposed a method that integrates demographic and survival analysis, discrete event simulation, and optimization. Also, developed a decision support system to use in practice.

# Chapter 4

## *Long Term Care Analysis in Nova Scotia*

---

In this chapter, we present and study the data gathered from Nova Scotia's Department of Health and Wellness: Continuing care [38]. The data was collected and then analyzed in response to the problems posed in chapter 1 of this thesis. The collected data consists of:

(A): The first dataset contains information on home care agencies weekly waitlist in the different DHAs across Nova Scotia (November 2014).

(B): The second dataset sums up LTC placements in the different NHs and RCFs across Nova Scotia's DHAs (2008-2014).

(C): The third dataset represents a LTC waitlist according to patient type (community/hospital) and type of placement in the different DHAs in Nova Scotia (December 2014).

(D): The fourth dataset shows the number of funded beds in most LTC facilities (NH, RCF) in the different DHAs across Nova Scotia (March 2014).

The fundamental goal of this data analysis is studying on the real data of number of beds, placements, and people in pending state in 9 DHAs. Finding the turnover rate of beds in those DHAs and have conclusions and recommendations.

### 4.1. Data Analysis

The Datasets files used for these analysis are: (B), (C) and (D). With these acronyms:

C: From Community    H: From Hospital    T: Inter-facility Transfer

NHS: Nursing Home    RCFS: Residential Care Facilities    SO: Society/Community Options

		DHA ("*" means NH and RCF in one location; "***" means not SEA)								
		1	2	3	4	5	6	7	8	9
<b>Number of beds in NHs</b>	1	143	62	53*	125	10	201	15	59*	190
	2	50	35	50	36	73	36	39	36	50
	3	60	66	117	35	96	46	50	60*	111
	4	43	36	142	59*	65	36*	59*	270	28*
	5	61	104	49	89	36	112	59*	19	72
	6	39	89	107	60	14		136	71	31
	7	89	85	62	61			25**	50*	51
	8		72	67	40*			24	36*	87
	9								144	31*
	10								85	123
	11								113	29
	12								36	130*
	13								22	445*
	14								110	111
	15								52	176
	16								24	190
	17								18	149
	18								18	65
	19								11	41
	20								8	36*
	21									107
	22									58
<b>Total</b>		485	549	647	505	294	431	407	1242	2311
<b>Standard deviation</b>		36.42	24.47	35.89	30.68	34.51	71.59	38.17	61.59	92.77
<b>Total/Stdev</b>		13.32	22.43	18.03	16.46	8.52	6.02	10.66	20.17	24.91
<b>Note: "117" is that DHA 3 has 97 beds for adults and 20 beds for children</b>										

**Table 4.1:** Number of beds in nursing homes (NHs) in 9 districts.

		DHA ("*" means NH and RCF in one location; "***" means not SEA)								
		1	2	3	4	5	6	7	8	9
<b>Number of beds in RCFs</b>	1	29	22	12*	8	43	27	35	11*	24
	2	8	19	20	3	14	17*	6*	12	4*
	3	6	14	25	6	40	29	8*	4	60*
	4	15	11	8	6	24			3	26*
	5		23**	25	12*				10*	40*
	6			15**	51				13*	4
	7			23	8				13*	20
	8				20*				16	3
	9								3	4
	10								11	3
	11									6
	12									3
	13									13*
	14									12
<b>Total</b>		58	89	128	114	121	73	49	96	222
<b>Standard deviation</b>		10.41	5.17	6.73	15.72	13.67	6.43	16.20	4.62	17.00
<b>Total/Stdev</b>		5.57	17.22	19.03	7.25	8.85	11.35	3.03	20.76	13.06
<b>Total NHs/RCFs</b>		8.36	6.17	5.05	4.43	2.43	5.90	8.31	12.94	10.41

**Table 4.2:** Number of beds in residential care facilities (RCFs) in 9 districts.

Year	Facility	DHA1	DHA2	DHA3	DHA4	DHA5	DHA6	DHA7	DHA8	DHA9
FYTD 2011/12	NH	236	276	288	160	142	192	179	401	849
	RCF	17	25	37	47	53	25	16	59	90
	NH+RCF	253	301	325	207	195	217	195	460	939
FYTD 2012/13	NH	228	252	287	163	122	210	158	382	868
	RCF	20	26	37	50	54	30	10	51	58
	NH+RCF	248	278	324	213	176	240	168	433	926
FYTD 2013/14	NH	188	228	280	184	141	172	167	386	930
	RCF	22	16	38	41	36	30	11	51	65
	NH+RCF	210	244	318	225	177	202	178	437	995

**Table 4.3:** Number of placements in 9 DHAs (2011-2014).

There are few questions we want to answer:

***4.1.1. Question 1: Whether 9 District Health Authorities (DHAs) have different turnover rates on beds in: NHs, RCFs, and combination of (NHs and RCFs)?***

$$\frac{\text{Number of placements during a year}}{\text{Available beds for one year}} = \text{Average turnover for one year}$$

***4.1.1.1. In Nursing Homes (NHs):*** For each of the three years (2011-2014), we calculate the turnovers; we divide the number of placements by/the number of beds in NHs.

Turnover rate (NHs)	DHA1	DHA2	DHA3	DHA4	DHA5	DHA6	DHA7	DHA8	DHA9
FYTD 2011/12	0.4866	0.5027	0.4451	0.3168	0.4830	0.4455	0.4398	0.3229	0.3674
FYTD 2012/13	0.4701	0.4590	0.4436	0.3228	0.4150	0.4872	0.3882	0.3076	0.3756
FYTD 2013/14	0.3876	0.4153	0.4328	0.3644	0.4796	0.3991	0.4103	0.3108	0.4024

**Table 4.4:** Turnover rate in NHs.

By using the **one-way ANOVA** analysis, the results show the average rates of 9 DHAs are different.

By using the **Tukey-Kramer method test** at the level 0.05, we test and identify which two of the 9 DHAs are different (marked by the sign: “√” in the table below). The results show that the turnovers rates of NHs in (DHA4 and DHA8) are significantly lower than most of other DHAs.

Turnover rate (NHs)	DHA1	DHA2	DHA3	DHA4	DHA5	DHA6	DHA7	DHA8	DHA9
DHA1				√				√	
DHA2				√				√	
DHA3				√				√	
DHA4	√	√	√		√	√			
DHA5				√				√	
DHA6				√				√	
DHA7								√	
DHA8	√	√	√		√	√	√		
DHA9									

**Table 4.5:** Tukey-Kramer method test results for turnover rate for NHs

**4.1.1.2. In Residential Care Facilities (RCFs):** For each of the three years, we divide the number of placements by/the number of beds in RCFs.

Turnover rate (RCFs)	DHA1	DHA2	DHA3	DHA4	DHA5	DHA6	DHA7	DHA8	DHA9
FYTD 2011/12	0.2931	0.2809	0.2891	0.4123	0.4380	0.3425	0.3265	0.6146	0.4054
FYTD 2012/13	0.3448	0.2921	0.2891	0.4386	0.4463	0.4110	0.2041	0.5313	0.2613
FYTD 2013/14	0.3793	0.1798	0.2969	0.3596	0.2975	0.4110	0.2245	0.5313	0.2928

**Table 4.6:** Turnover rate in RCFs

By using the **one-way ANOVA**, the results show that the average rates of (9 DHAs) are different.

By using the **Tukey-Kramer method test** at the level 0.05, we test and identify which two of the 9 DHAs are different (marked by the sign: “√” in the table below). The results show

that the turnovers rates of NHs in (DHA4 and DHA8) are significantly higher than most of other DHAs.

Turnover rate (RCFs)	DHA1	DHA2	DHA3	DHA4	DHA5	DHA6	DHA7	DHA8	DHA9
DHA1								√	
DHA2								√	
DHA3								√	
DHA4									
DHA5								√	
DHA6								√	
DHA7								√	
DHA8	√	√	√		√	√	√		√
DHA9								√	

**Table 4.7:** Tukey-Kramer method test results for turnover rate in RCFs

***4.1.1.3. In Nursing Homes and Residential Care Facilities (NHs and RCFs):*** For each of the three years (2011-2014), we calculate the turnovers by dividing the number of placements by/the number of beds in both (NHs and RCFs).

Turnover rate (NHs & RCFs)	DHA1	DHA2	DHA3	DHA4	DHA5	DHA6	DHA7	DHA8	DHA9
FYTD 2011/12	0.4659	0.4718	0.4194	0.3344	0.4699	0.4306	0.4276	0.3438	0.3707
FYTD 2012/13	0.4567	0.4357	0.4181	0.3441	0.4241	0.4762	0.3684	0.3236	0.3656
FYTD 2013/14	0.3867	0.3824	0.4103	0.3635	0.4265	0.4008	0.3904	0.3266	0.3928

**Table 4.8:** Turnover rate in NHs and RCFs

By using the **one-way ANOVA** analysis, the results show the average rates of 9 DHAs are different.

By using the **Tukey-Kramer method test** at the level 0.05, we test and identify which two of the 9 DHAs are different (marked by the sign: “√” in the table below). The results show

that the turnovers rates of NHs and RCFs in (DHA4 and DHA8) are significantly lower than most of other DHAs.

Turnover rate (NHs & RCFs)	DHA1	DHA2	DHA3	DHA4	DHA5	DHA6	DHA7	DHA8	DHA9
DHA1				√				√	
DHA2				√				√	
DHA3								√	
DHA4	√	√			√	√			
DHA5				√				√	
DHA6				√				√	
DHA7									
DHA8	√	√	√		√	√			
DHA9									

**Table 4.9:** Tukey-Kramer method test results for turnover rate in NHs and RCFs

Finally, by the **one-way ANOVA**, it shows that the average turnover rate of each of three years is not different. It means that over all, the average turnover rate from 2011 to 2014 does not have significant change. It is reasonable to have the following **Assumption**: The lifetime distribution is the same in every DHA of those 9 DHAs. *Under this assumption, we can conclude that the vacancy rates of beds in DHA4 and DH8 are significant higher than the other DHAs, but we cannot identify the exact reasons.*

#### **4.1.1.4. Discussions**

Below is a table representing results from a research done in 2009-2010 on data from all DHAs in Nova Scotia about: The percentage, number, nature of LTC patients. These results might be used to explain the results we got in our analysis:



<b>DHA</b>	<b>Average Seniors Waiting</b>	<b>% Total Seniors Waiting</b>	<b>% of (Provincial Population (75+))</b>	<b>% All LTC Beds</b>
<b>1</b>	70	5%	8%	10%
<b>2</b>	54	4%	8%	8%
<b>3</b>	80	5%	10%	10%
<b>4</b>	155	10%	7%	8%
<b>5</b>	45	3%	6%	5%
<b>6</b>	83	5%	5%	7%
<b>7</b>	128	8%	5%	5%
<b>8</b>	465	31%	15%	16%
<b>9</b>	441	29%	36%	33%
<b>Total</b>	1521	100%	100%	100%

**Table 4.10:** Research results on LTC patients (75+) in Nova Scotia, 2009-2010 [30]

In 2009-2010, DHA8, DHA9 and DHA4 had the longest LTC waiting lists with: 465, 441, 155 patients. The LTC beds proportions to the population (75+) proportions are closely aligned. However, the demand for LTC placement in DHA 8 related to their population (75+) is higher than the rest of the province.

In DHA 4 and DHA 8, the demand for LTC (10%, 31% of provincial waitlist) is quite high in comparison with the other DHAs, and not explained by the insufficient available bedding (8%, 16% of total provincial LTC beds),

In DHA 4 and DHA 8, the demand for LTC (10%, 31% of provincial waitlist) is high in comparison with other DHAs, and not explained by the high proportion of provincial seniors 75+ (7%, 15%),

We suspect three reasons why the turnover rate is lower in DHA4, and DHA8:

(1) Patients 75+ years old tend to have more health complications, need more care, consume more resources, and have a long LOS time, that's why these care facilities in DHA4 and DHA8 tend to keep patients for longer, because LTC would be a must in age (75+). It is not the case for patients (65+) who tend to have less complicated conditions and LTC is not a must, and they have other care options choices. It might be the reason why other DHAs with younger patients percentage tend to have a higher turnover rate (younger patient choose to leave LTC for better care).

(2) Another reason might be the combination of: Long admission process, policy allowing patients for up to 5 LTC application at once, and policy giving patients up to 3 months to decide if to accept or refuse a bed offer at a LTC facility. DHA 4 and DHA 8 have higher LTC demand from patients (75+). These patients are very needy and frail (go to heaven while in LTC facilities), and this leaves the facility with vacant beds. However, these beds can't be assigned to patients in the waiting list in a rapid rate, because of the long acceptance process, and patients waiting too long to decide if they accept or refuse the offer (3 months). Also, allowing patients to apply for different facilities, accept the most convenient offer, and refuse the other offers will complicate the situation not only by making the waiting list long, but also vacant beds increase and idle staffs.

(3) Another possible reason for low turnover in DHA4 and DHA8 is the mismatch between the beds count and facilities staffs. These facilities might be refusing to accept new patients even they have available vacant beds because they might not have the skilled staffs to take care of extra patients. Especially that these facilities (DHA4, DHA8) are known to have a high level of frail elderly. Thus, these facilities might be lacking staffs' management.

The high vacant beds in DHA4 and DHA8 might also be related to the long admission process and patients' age (75+). How? Most of their applications are from patients 75+ who tend to go to heaven while served LTC. Also, it is known from the data we had from [38] that patients are allowed to apply for 5 different LTC facilities maximum, and in most cases patients (either 65 or 75+) apply for different facilities simultaneously to ensure faster acceptance in case of future health deterioration. The above, makes the waiting list longer and the admission process slower. All the mentioned reasons result in high number of vacant beds and impossibility to accept new patients rapidly (low turnover rate).

Another reason for high vacant beds in DHA8 and DHA4 might be: A mismatch in management and communication between their health authorities, DHW and LTC facilities management. How? It is known that low numbers of available long-term care beds limits the number of placements. It is not the case for DHA8, which has low placement rate and high vacant beds number. In general, the length of time it takes to fill each vacant bed is affected by how efficiently DHW, DHAs and providers work together to manage the placement process [28]. Cape Breton DHA (DHA4) might be slower than other DHAs in sending patients' information to LTC facilities. This cause was reported in a 2009 research on the different reasons of high vacant beds [28].

DHA 9 does not have low turnover rate in our results although it has one of the lengthiest waiting lists, and the highest 75+ population, is because it has more beds counts (33% of the overall province beds count) in comparison with DHA4 and DHA8 (8%, 16% of the overall provincial beds count). In this case patients may not wait so long as they have more available and better-managed beds. This may be the reason why it has a high turnover

rate (available resources and better management as it is the most important DHA in the province).

Long-term care beds become available (vacant) primarily due to the death of a resident, a request to transfer to another facility or by adding additional beds to the system [28]. In DHA8, most patients are (75+) which increases the death rate in their facilities. Also, Cape Britain tends to be a retirement province and it is understandable that people want to transfer to facilities close to their family members. Also, in 2010 (April-June), the government added new beds to most facilities across the province, with more focus on adding more in Cape Breton DHA [30].

Another possible factor for high vacant beds, low turnover rate and long waiting list in DHA8 and DHA4 is high transfer rate between facilities. Like it is shown in table below, DHA8 and DHA4 has among the highest transfer rates and the highest community patients after DHA9, and this is increasing the waiting time and complicating the placement process.

<b>District</b>	<b>Community</b>	<b>Hospital</b>	<b>Subtotal H/C</b>	<b>Transfer</b>	<b>DHA Totals</b>
<b>1</b>	94	12	106	74	180
<b>2</b>	135	19	154	62	216
<b>3</b>	184	28	212	95	307
<b>4</b>	225	16	241	137	378
<b>5</b>	44	17	61	68	129
<b>6</b>	111	21	132	143	275
<b>7</b>	199	21	220	57	277
<b>8</b>	561	80	641	216	857
<b>9</b>	718	93	811	536	1347
<b>Totals</b>	<b>2271</b>	<b>307</b>	<b>2578</b>	<b>1388</b>	<b>3966</b>

**Table 4.11:** LTC waiting list (Hospital, Community, Transfer), by DHA [38]

***4.1.2. Question 2: Whether 9 District Health Authorities (DHAs) have different waiting time for the combination of (NHs and RCFs)?***

To answer this question, we use the data of pending: the number of weekly patients pending placement for a NH or RCF in each DHA, from April 2<sup>nd</sup> to December 3<sup>rd</sup>.

<b>Time</b>	<b>DHA1</b>	<b>DHA2</b>	<b>DHA3</b>	<b>DHA4</b>	<b>DHA5</b>	<b>DHA6</b>	<b>DHA7</b>	<b>DHA8</b>
<b>Apr 2</b>	54	51	71	76	27	38	70	143
<b>Apr 9</b>	48	52	72	73	25	34	74	146
<b>Apr 16</b>	45	46	68	74	23	34	76	148
<b>Apr 23</b>	44	48	66	73	21	26	74	151
<b>Apr 30</b>	44	51	63	66	19	28	75	152
<b>May 7</b>	47	51	55	61	16	32	65	153
<b>May 14</b>	47	50	63	61	15	29	56	153
<b>May 21</b>	49	54	66	64	21	28	60	159
<b>May 28</b>	47	57	68	63	19	27	65	166
<b>June 4</b>	44	54	68	68	19	28	69	166
<b>June 11</b>	49	53	74	72	19	28	73	171
<b>June 18</b>	45	52	84	79	21	26	73	172
<b>June 25</b>	44	47	84	81	25	23	71	180
<b>July 02</b>	44	47	84	81	25	23	71	180
<b>July 09</b>	53	44	83	75	20	23	80	172
<b>July 16</b>	53	44	83	75	20	23	80	172
<b>July 23</b>	54	51	87	77	24	36	78	176
<b>July 30</b>	51	52	88	83	25	35	82	189
<b>Aug 06</b>	53	49	87	80	26	35	80	194
<b>Aug 13</b>	54	50	88	76	24	36	81	197
<b>Aug 20</b>	55	50	87	77	25	45	82	211
<b>Aug 27</b>	55	50	87	77	25	45	82	211
<b>Sep 03</b>	61	56	92	83	22	46	84	201
<b>Sep 10</b>	61	58	91	82	18	45	86	207
<b>Sep 17</b>	57	60	93	83	16	44	88	203
<b>Sep 24</b>	39	42	69	65	15	36	77	150
<b>Oct 1</b>	40	43	71	64	11	36	81	163
<b>Oct 8</b>	42	47	78	57	16	35	83	166
<b>Oct 15</b>	45	51	87	60	18	35	81	177
<b>Oct-22</b>	44	47	92	78	21	40	86	187
<b>Oct-29</b>	44	50	96	79	22	38	85	191
<b>Nov 05</b>	46	49	104	78	23	35	88	194

<b>Nov 12</b>	47	51	107	73	25	35	88	201
<b>Nov 19</b>	51	53	99	72	20	30	87	200
<b>Nov 26</b>	52	53	100	75	20	28	87	207
<b>Dec-03</b>	53	56	101	79	22	34	89	210

**Table 4.12:** Number of weekly patients pending placement for a NH or RCF by DHA

**4.1.2.1. Solution Steps**

First, obtain the average turnover rate for (NHs and RCFs) of three years (2011 to 2014) in each DHA. Second, multiply the total number of beds in (NHs and RCFs) by the average turnover rate of three years in each DHA. The result is the available beds of one year in each DHA. Third, divide the weekly pending patients' number in each DHA by the available beds of one year in each DHA to obtain the average waiting time of a new comer.

$$\text{Average turnover of 3 years(each DHA)} \times \text{Total number of beds}$$

$$= \text{Available beds for 1year}$$

$$\frac{\text{Number of pending patients each week}}{\text{Available beds for one year}} = \text{Average waiting time of new patient}$$

By the **one-way ANOVA**, it shows that the average waiting times between 9 DHAs are different.

By the **Tukey-Tramer method test** at the level 0.05, we identify which two DHAs have a different waiting time. Mark it by “√” in the table below. The average waiting times are significantly different among most of DHAs.

Turnover rate of NH+RCF	DHA1	DHA2	DHA3	DHA4	DHA5	DHA6	DHA7	DHA8	DHA9
DHA1			√	√	√	√	√	√	√
DHA2			√	√	√	√	√	√	√
DHA3				√	√	√	√	√	
DHA4	√	√	√		√	√	√	√	√
DHA5	√	√	√	√		√	√	√	√
DHA6	√	√	√	√	√		√	√	√
DHA7	√	√	√	√	√	√		√	√
DHA8	√	√	√	√	√	√	√		√
DHA9	√	√		√	√	√	√	√	

**Table 4.13:** Tukey-Kramer method test results for waiting time in NHs and RCFs

Finally, the **one-way ANOVA** shows that the average waiting time between 36 weeks, from April 2<sup>nd</sup> until December 3<sup>rd</sup>, does not have significant change.

The average waiting time depends on the turnover rate and the arriving rate. Thus, a lower turnover rate may not result into a higher waiting time.

Average Waiting Time	DHA1	DHA2	DHA3	DHA4	DHA5	DHA6	DHA7	DHA8	DHA9
Years	0.2064	0.1842	0.2547	0.3411	0.1145	0.1516	0.4324	0.4022	0.2462
Days	76.3	67.7	95.3	125.7	43.1	57.5	159.5	148.9	90.1
9 DHAs	108.9 days								

**Table 4.14:** One-way ANOVA test results for 9 DHAs

#### 4.1.2.2. Discussions

The average LTC waiting period for community patients in NS province increased from 110 days in 2009-10 to 150 days in 2010-11 [30]. From the average waiting time in our results (data of 2011-2014), we still can obtain the initial idea on the system performance: [110 - 108.9 = 1.1, 150 - 108.9 = 41.1]. This means that most of the waiting time is at pending state. Thus, it is unlikely for managers to reduce the waiting time if they focus on discharge

process. Two possible ways to reduce waiting time: (1) adding resources; (2) reduce the vacancy rates of beds: If a person is at pending state, it does not mean that this person can be assigned at once when a bed is available. Two possible reasons are that the person may not satisfy the facility policy, or he/she is not satisfied with the offer (a patient has a period of 3 months to take or refuse an offer, and during that period the assigned bed is vacant and won't be offered to someone else until the patient dismiss the offer). The key to that is that the patient's demand is different from the admission evaluation process. Above all, if the managers cannot let the demand match the supply well, the solution will be only adding resources.

The average LTC waiting period for hospital patients decreased from 80 days in 2009-2010 to 65 days in 2010-2011 [28]. This is a result of healthcare providers trying to elevate the pressure that ALC is having. Hospital patients are discharged from ALC and assigned to long-term care/home care as a priority in comparison with community patients. Thus, community patients list is increasing (110-150 days). Hospital patients' LTC placements are twice that of community patients [30].

We got data from the DHW (2014) about (Hospital, Community, Transfer) waiting times in the 9 DHAs in Nova Scotia, presented in the figure below:



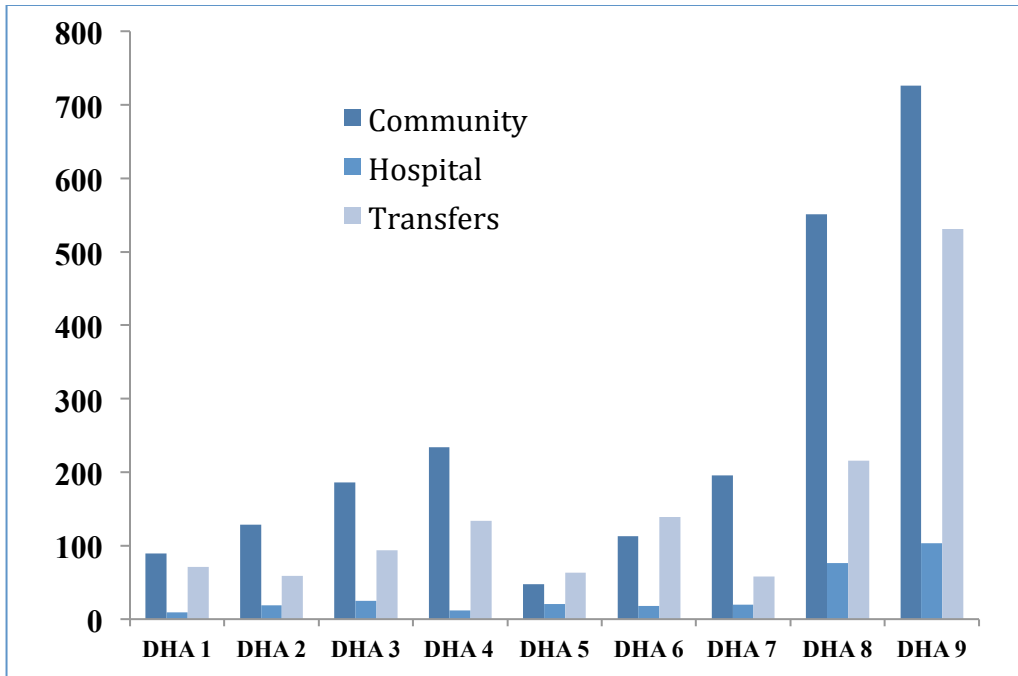

**Figure 4.1:** Average waiting time across NS (Hospital, Community, Transfer), 2014 [33]

Source: Department of Health and Wellness, 2014

According to the results, it seems that the same problem is still persistent from 2009-2014. Like already said, it is understandable that DHA9 has higher waiting times (community/hospital) than other DHAs, because it is the main DHA and has higher population. The problem may be solved because DHA9 has the highest bed counts and staffs.

The median wait time for DHA8 clients (hospital/community) is quite high in comparison with other DHAs. When you break out the hospital clients from those living in community, data shows that the wait times for hospital clients are very similar (high). This is the only area of the province that exhibits this trend. The DHW and CBDHA are aware, and staff is looking into possible reasons that might account for this finding, one could be reporting issues that may be causing the hospital wait time to be inflated [33]. DHA4 comes next with average wait times (community/hospital), however when you break out hospital

clients from community clients, hospital's waiting time tends to decrease. The figure below shows the dilemma of the waiting times for year (2010-2011) from both the community and hospital separately [30].

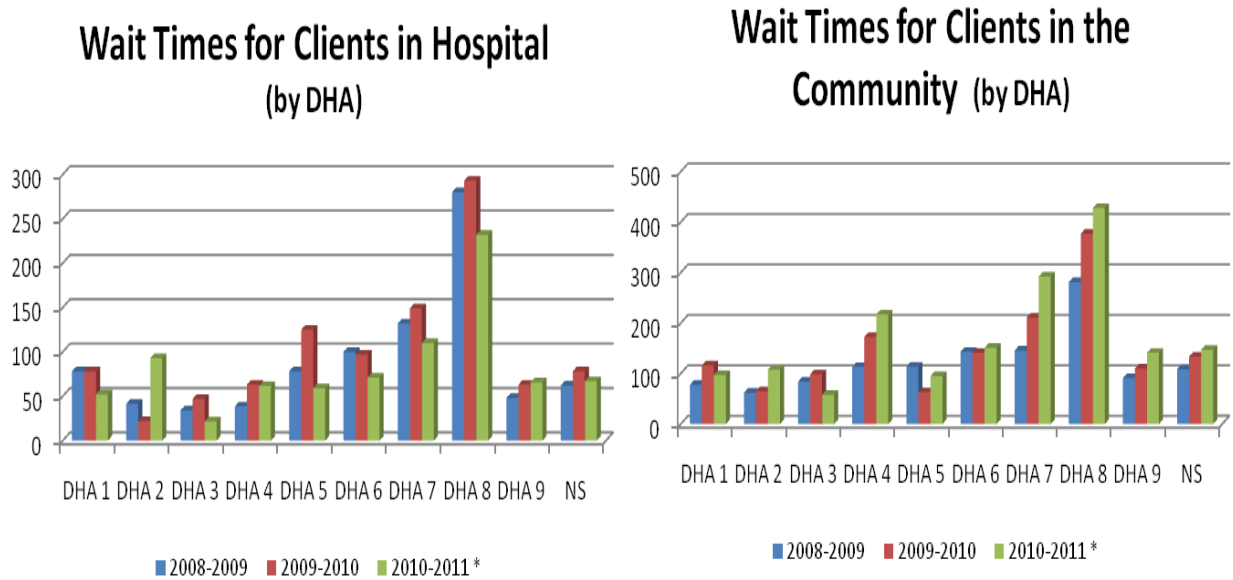

**Figure 4.2:** Waiting times for hospital and community clients, NS (2009-2011)

**4.1.3. Question 3: Whether the turnover rate relates to coefficient of variation in NH, RCF, and the combination of NH and RCF?**

By the Spearman rank correlation coefficient test, there is no enough evidence to believe that the turnover rate and the coefficient of variation related.

**4.1.4. Question 4: Whether the turnover rate relates to proportion between the number of beds in NH and RCF?**

By the Spearman rank correlation coefficient test, there is no enough evidence to believe that they are related. We also tried several different other measures, but no one relates to the turnover rate. Thus, these conclusions suggest that we do not have to be

sensitive on the size of NH and RCF. In other words, there is no significant difference between building several small NH (or RCF) and building a large NH (or RCF).

The vacancy rates of beds in DHA4 and DH8 are significantly higher than the others, the reason is not the scale or distribution of beds in NH or RCF. There should be some other reasons.

It is not strange to have close turnover rates. The DHAs in Nova Scotia follow the same placement policy no matter what the policy is, more exactly when the policy is independent of any certain DHA. Under this situation, one key factor on turnover rate is the lifetime distribution, which is relative objective factor and independent of any DHA.

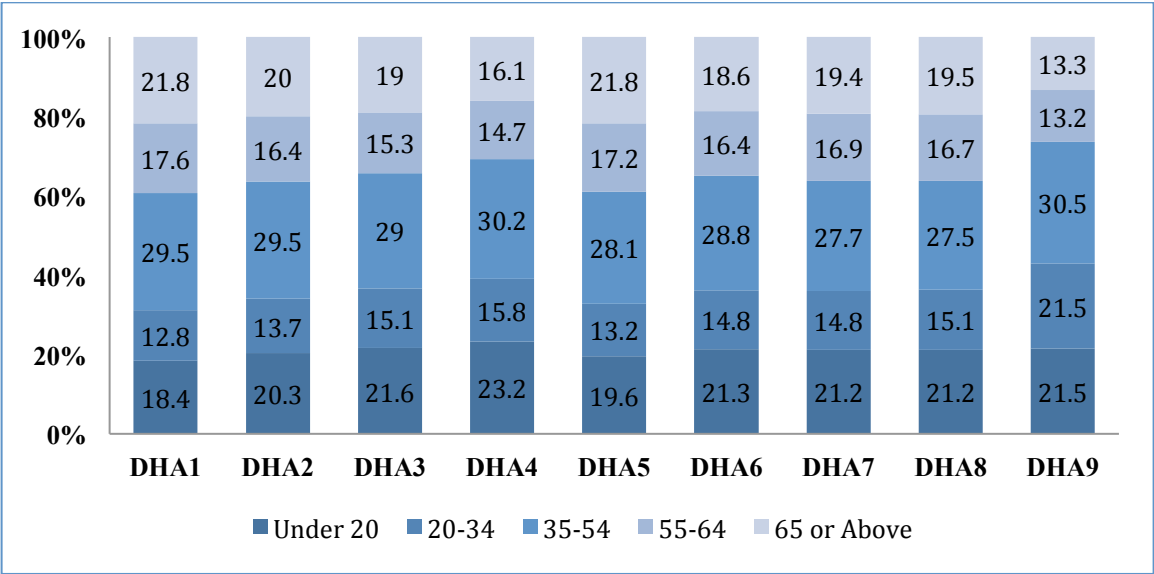

**Figure 4.3:** Nova Scotia’s DHAs population, by age Groups (2011) [82]

DHA #	# Total population, 2011	# Population 65+ of total DHA population, 2011	# Population 65+ of total NS population, 2011	# Population 75+ of (Provincial population 75+), 2009	# Total provincial LTC waiting list, 2009
DHA1	58.270	12.703 (21.8%)	12.703 (1.38%)	6.000 (8%)	70 (5%)
DHA2	57.810	11.562 (20.0%)	11.562 (1.26%)	6.000 (8%)	54 (4%)
DHA3	81.345	15.456 (19.0%)	15.456 (1.68%)	7.500 (10%)	80 (5%)
DHA4	71.070	11.443 (16.1%)	11.443 (1.25%)	5.250 (7%)	155 (10%)
DHA5	31.355	6.836 (21.8%)	6.836 (0.70%)	4.500 (6%)	45 (3%)
DHA6	45.645	8.490 (18.6%)	8.490 (0.93%)	3.750 (5%)	83 (5%)
DHA7	43.745	8.487 (19.4%)	8.487 (0.92%)	3.750 (5%)	128 (8%)
DHA8	119.955	23.392 (19.5%)	23.392 (2.54%)	11.250 (15%)	465 (31%)
DHA9	412.530	54.867 (13.3%)	54.867 (5.95%)	27.000 (36%)	441 (29%)
<b>Nova Scotia</b>	Total: 921.725		Total: 921.725	65-74: 85.000 75-84: 48.000 65+: 115.000 <b>75+: 75.000</b> 85+: 22.000	1521(100%)

**Table 4.15:** Population in Nova Scotia and DHAs, (2011) [82]

The table above show that population percentage for age group (65+) in different DHAs is quit different. DHA9, DHA8, DHA3, DHA4 have highest total population counts. After calculations, DHA9, DHA8, DHA1, DHA3, DHA2, DHA4 (in order) have highest counts of seniors (65+). This may support our findings that DHA8 and DHA4 LTC list has the highest counts of seniors aged (75+).

The figure below shows that life expectancy in DHA8 is the lowest in comparison with others; this may support the point that LTC patients go to heaven while being in nursing home. As a results, having more vacant beds. Low turnover rate may be caused by placement office communicating information in slow rate and its difficulty dealing with the high level of LTC applications (DHA8 has the longest waiting list). However, in DHA4 life

expectancy is pretty high; this supports the fact that this DHA has low turnover rate. While high vacancy is caused by lack of coordination between DHA-placement office and LTC facility management.

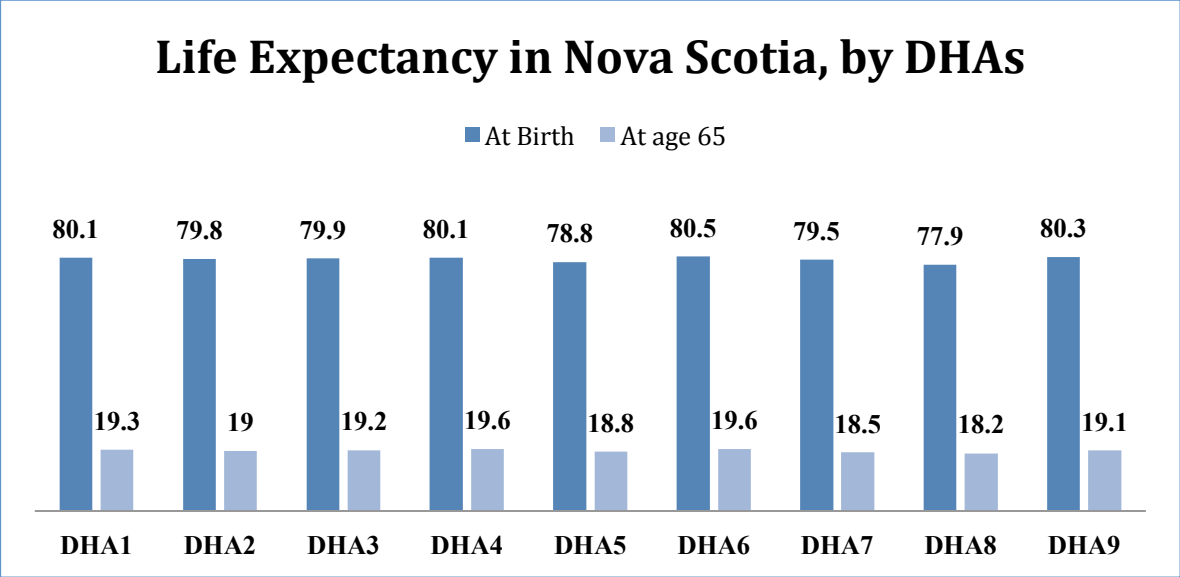

**Figure 4.4:** Life expectancy in Nova Scotia, by Birth/Age 65, by DHA [83]

Finally and according to our previous discussion (previous research and our findings), the more supported causes of low turnover rate, high vacant beds, and long waiting list in DHA4 and DHA8 are:

1. Difficulty dealing with the high level of applications by the placement office.
2. Inefficient communication between (DHAs, placement office, and LTC providers) during the placement process.
3. Difference in Lifetime distribution between DHAs.

## 4.2. Vacant Beds Causes & Barriers Identified by NHs Providers

In August 2010, 81 nursing home providers were contacted to give their perception regarding bed vacancies and difficulties getting their beds filled efficiently. Here is their response list [30]:

1. Variation in the length of bed vacancies around the province, with many homes reporting lengthier bed vacancies than in the past.
2. Variation in the time it takes Nursing homes providers to receive client information once a bed vacancy is declared.
3. Nursing homes care providers have a positive relationship with DHW placement staff, but placement offices members were too slow to deal with the volume of work.
4. *Personal Directives Act* has created new challenges for facilities and Care Coordinators because it takes time to be understood, leading to delays in both transfers and new placements of clients.
5. Opening of new facilities has diverted attention from regular placements and has increased the volume of inter-facility transfers leading to lengthier bed vacancies.
6. Facility requirements of a pre-admission assessment and family visit to sign a financial contract creates challenges.
7. Families are not fully prepared to make decisions regarding placement in a timely manner.
8. Changing and complex needs of clients upon admission create challenges.
9. Unavailability of physicians to participate in the admissions process.
10. Reporting on bed vacancies is not coordinated and is limited. Providers notify the Placement Office shortly after a vacancy occurs to initiate a new placement. However, there is no reporting on the date the client moves into the facility. Providers also report the sum of vacant bed days to DHW. But, the data on the duration of each bed vacancies is not reported [See Appendix: Definitions Glossary].

### 4.3. LTC Admission-Discharge-Transfer Policy

The Department of Health, District Health Authorities, Long term care providers, Hospital and Home care providers share the responsibility for the post discharge-placement process. Each participates in the process to facilitate clients' transitions from the community, hospital, or a long-term care facility to another long-term care facility [30].

Clients applying for or being transferred to any form of continuing care are assessed using a standardized assessment tool: Inter RAI- (LTC-HC-AC-...), which aims to improve health care for persons who are elderly, frail, or disabled. RAI assessments are completed by the Care Coordinator with the participation of the client, family and others involved in their care and support with the focus on quality of life by assessing client needs, strengths and preferences. The RAI assessment scales are as follows [30]:

**Client's Cognitive Performance Scale:** 0-6 scale with higher scores indicating more significant cognitive impairment.

**The MAPLe Level:** 1-5 scale used as an indicator of risk for adverse outcomes including caregiver distress. Higher MAPLe levels indicate more risk for adverse outcomes.

**CHESS:** 0-5 scale used as a measure of clinical instability and a predictor of mortality.

**ADL Self Performance Hierarchy:** 0-6 scale with higher score indicating greater dependence with ADL performance.

The date of care level approval becomes the client's "waitlist date". Clients' placements are offered in order of their waitlist date. LTC providers notify the Placement Office (PO) about a bed vacancy, the PO then sends information regarding the next client on the facility's wait list to the provider. The provider reviews the client information and notifies the PO about their decision. The PO then contacts the client to offer the 'bed'. The

client or substitute decision-maker informs the PO of their decision, and further arrangements are made with the LTC provider to arrange for the client's admission. A client is considered ready to receive a bed offer once she/he has been assessed, has a care level decision approval, financial accommodation rate determined and has identified their facility preferences [30]. Patients are placed according to the process described above. Hospital patients are in priority than community patients, however, exceptions occur.

Usually, patients are placed in facilities 100 kilometers far from home (family members), and are allowed to choose as many LTC facilities to appear on their wait list (Unlimited in NS, and only 5 facilities in Ontario). Patients had a period of 3 months for a placement decision after a bed offer (This is not in action starting: March 15, 2015). Now, they have to accept or refuse the bed offer in 24 hours [84].

LTC providers are funded by the funding received by LTC providers is based upon a facility's entire budget and is not linked to whether a resident occupies a bed or not. The occupancy rate is no longer used in funding LTC facilities. Prior to January 1, 2005, LTC service providers were funded based upon occupied bed days, using an occupancy rate. Residents pay an accommodation rate to their LTC provider, which is set by DHW each November 1st. Residents with lower net income have their fees reduced [30].



# Chapter 5

## Queuing Models for Long Term Care Optimization

According to the Department of Health and Wellness (2014), and what we already stated in previous chapters, the ALC system in Nova Scotia could be presented as shown in the diagram below [38]:

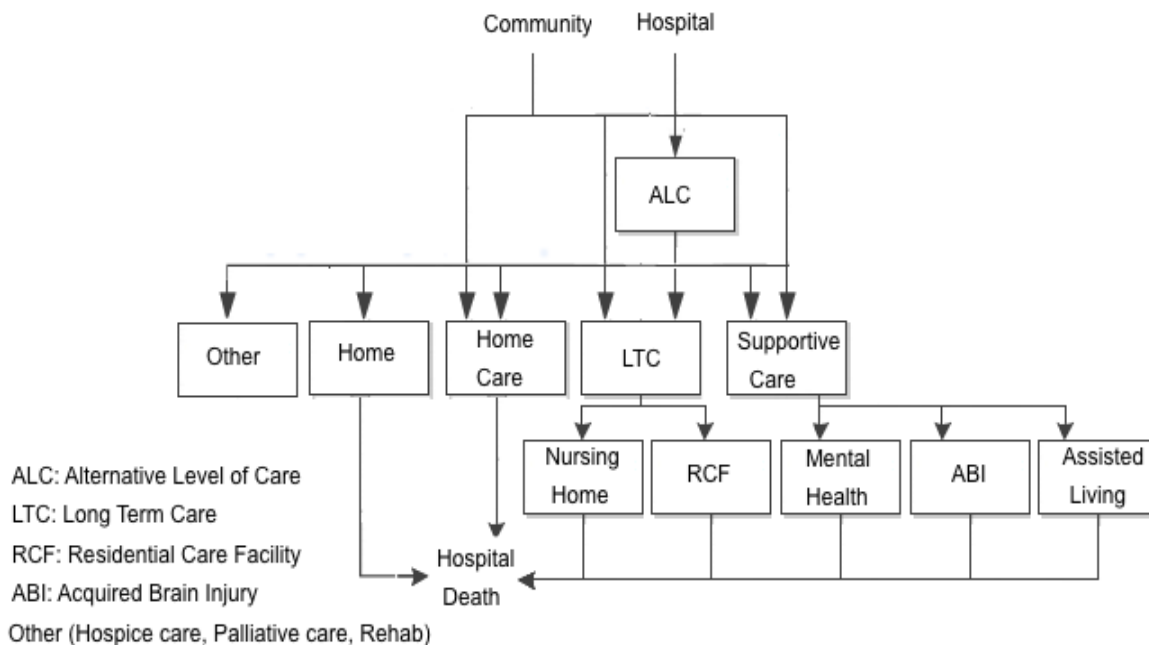

**Figure 5.1:** Alternative level of care in Nova Scotia, 2014 [38]

As illustrated in the figure, there exist at least eight possible ALC destination facilities (nodes). We will call this the Alternative level of care/Community Care network (ALCCN). ALC Patients' RAI score and service guidelines determine their appropriate facility destination (node). The definition of each node is provided in the Appendix and Chapter 3. The demand for the ALCCN facilities comes from the hospital and the community, as shown in the diagram. This means that patients in the hospital are in

competition with those from the community who already experienced lengthy wait times in order to get access to the same resources. Modeling capacity requirements for the ALCCN facilities must include this significant segment of demand. Thus, our model will include both ALCC and community demand for the ALCCN. A well performing system must maintain balanced patients' number and reasonable wait times for both hospital and the community. We've been asked to only consider: Home care (with support), nursing homes, supportive care (as a whole facility), ALC, and (RCF, other, home (without support)) would be omitted and neglected. The reason is that Nova Scotia's government is willing to cut of financing RCF in the long run and consider home care as a future potential solution for ALC congestion and waiting time challenge [38]. Two methods are used to solve the ALCCN waiting time, long waiting list problem:

## 5.1. Method I: Using Markov Chains

### **5.1.1. Model Description**

Like previously mentioned, In Nova Scotia's ALCCN, ALC exit and LTC entrance nodes are the most congested. We will decompose ALC node to sub-entities (Hospitals) and LTC node to sub-entities (Nursing homes). We may focus on one Nursing home (facility) instead of the whole system since the whole system will be improved if every Nursing home (facility) can be improved. However, our model may be applied on the entire LTC system in Nova Scotia or its sub-entities (NHs, RCFs, Hospitals...etc) because it has the no loss of generality property. Lets describe the model for one nursing home and apply the simulation on the entire LTC system. A Discrete period model is used to measure the average waiting time of seniors in a Nursing home of the Continuing care system. We assume that the unit of time period is one day. Also, we assume that seniors are served under the first-come-first-

served discipline (FCFS). Let  $b$  be the budget per Nursing home per period, which is the only decision variable in our problem. The patient departure rate is  $K(b)$  each period, where  $K(b)$  is a non-decreasing function of  $b$ . In each period, the events happen in the following order: (1) Observe the number of patients in the queue; (2) Serve  $K(b)$  patients; (3) Accept new patients at the end of a period. In this method we will be using two approaches and observe how they effect the waiting time of the LTC system for Nova Scotia's government:

(1) Expanding Approach: The government budget  $b$  amount of money each period for each nursing home in the LTC system to shorten the waiting time. Let  $w_{pu}(b)$  be the expected total waiting time of LTC system and  $\bar{w}_{pu}(b)$  be the corresponding average waiting time when investment is  $b$ . The point behind this approach is to use the extra budget to fill the free available space (cover the gap) in LTC nursing homes in order to expand the capacity [85].

(2) Shunting Approach: The government provides vouchers to seniors to use a LTC services package. The LTC services are a service package divided into services from a lot of providers in the society (Private care facilities, Individuals offering home care, ...etc.). Suppose the total amount of vouchers is  $v$  per period per senior. Motivated by the vouchers, some seniors will use package services. Suppose  $\alpha(v)$  portion of seniors will select package services if voucher value is  $v$ . Assume that the government budget the same amount  $b$  each period as in the expanding approach. If on the average there are  $m$  seniors using the package services each period, then the government will spend  $mv$  on vouchers and the remaining  $(b-mv)$  will be invested in the public LTC (Nursing homes). Consequently there will be fewer seniors in the public LTC system, so the average waiting time in the public LTC system is

shortened. We assume the waiting time is a constant  $w_{pr}$  in the package services and  $w_{pr} \geq 0$

Let  $w'_{pu}(b - mv, v)$  be the expected total waiting time and  $\bar{w}'_{pu}(b - mv, v)$  be the average waiting time of patients in the public LTC system in the shunting approach [85].

### The Model with Poisson Process and Constant Service Rate: M/D/s

First we present a traditional queue model. Assume that the arrival of seniors follows a Poisson process with arriving rate  $\lambda$  and service rate  $K(b)$ . For the expanding approach, the average waiting time of the public LTC system is given by this function:

$$\bar{w}_{pu}(b) = \frac{1}{K(b)} + \lambda \frac{1}{K(b)^2} \frac{1}{2 \left(1 - \frac{\lambda}{K(b)}\right)} = \frac{1}{K(b)} + \frac{1}{2(K(b) - \lambda)} - \frac{1}{2K(b)} = \frac{1}{2(K(b) - \lambda)} + \frac{1}{2K(b)} \quad (1)$$

If  $K(b)$  is an increasing concave and differentiable function,  $\bar{w}_{pu}(b)$  will be a convex and differentiable function. Then the optimal budget  $b$  can be obtained easily by taking the derivative of function (1).

In the shunting approach,  $\alpha(v)$  portion of patients will use the package services. Thus, in the public LTC system, the arrival of patients follows a Poisson process with a reduced arrival rate  $(1 - \alpha(v))\lambda$  and service rate  $K(b - mv)$ , and the average waiting time of the public service is given by the following function:

$$\bar{w}'_{pu}(b - mv, v) = \frac{1}{2[K(b - mv) - (1 - \alpha(v))\lambda]} + \frac{1}{2K(b - mv)} \quad (2)$$

Similarly, if both  $\alpha(v)\lambda$  and the service rate  $K(b - mv)$  are concave and differentiable, the optimal value of  $b$  and  $v$  will be obtained easily. Hence the performances of the two systems can be compared.

Although it is not difficult to evaluate the average waiting time in the model with Poisson process and constant service rate (M/D/s), the assumption differs from the fact that the system is never idle. Therefore, in the rest of this thesis, we will use another model to describe the system more realistically [85].

### **The Model with $(Q_1, Q_2)$ System: A Finite State Discrete Markov Chain**

We assume the LTC system is always busy so that new seniors have to wait in the queue whenever they arrive. The key to estimating the waiting time is to evaluate the probability distribution of the number of seniors in the system, which varies in the interval  $[Q_1, Q_2]$ . The number of seniors in the system at the beginning of a period represents the system state, denoted by  $s$ . Let  $A(s)$  be the arriving rate of seniors at state  $s$ , which is random and satisfies  $Q_1 \leq A(s) + s - K(b) \leq Q_2$  for any  $s$  and budget  $b$ . If  $A(s) = n$ , the probability density function of the length of the queue is  $P_{ij} = P(n)$  where  $i = s$  and  $j = n + s - K(b)$ . Then the transition probability matrix from state  $i$  to state  $j$  is defined as

[102]: 
$$T(b) \equiv [p_{ij}]_{(Q_2 - Q_1 + 1) \times (Q_2 - Q_1 + 1)}. \text{ And, } 0 \leq P_{ij} \leq 1, Q_1 \leq i, j \leq Q_2$$

In the shunting approach,  $\alpha(v)$  portion of seniors will select package services at voucher value  $v$ . We use the floor operator  $\lfloor \dots \rfloor$  to make the number of seniors an integer. Thus, when there are  $A(s)$  seniors arriving in one period,  $\lfloor \alpha(v)A(s) \rfloor$  seniors will choose package service and accordingly the rest  $A(s) - \lfloor \alpha(v)A(s) \rfloor$  of the seniors enter the public LTC system. The investment is  $(b - mv)$  in the public service. If  $A(s) = n$ , the probability density function becomes  $P_{ij} = p(n)$  where  $i = s$ ,  $j = n - \lfloor \alpha(v)n \rfloor + s - K(b - mv)$ .

Since the departure rate is a constant for any given  $b$ , the average waiting time of seniors in certain state is known. Thus, the key of evaluating the average waiting time of the LTC system is to know the proportion time of each state. We model the problem as a Markov chain with finite states. Without the loss of generality, suppose all states are irreducible. This means that all of the states are positive recurrent and there exists the unique stationary distribution, which is a row vector with dimensions  $1 \times (Q_2 - Q_1 + 1)$  and denoted by  $\pi(b)$  such that  $\pi(b) = (\pi_{Q_1}(b), \dots, \pi_{Q_2}(b))$ . Since the length of a period (one day) is much shorter compared with waiting time (waiting time may last from several months to several years). We will consider some queuing theory formulas; we assume the service time for a senior in a Nursing home is  $\frac{1}{K(b)}$  period [96]. In the expanding approach, according to Stationary

Distribution theorem:  $\pi$  Satisfies 
$$\begin{cases} \pi(b) = \pi(b)T(b) \\ \sum_j \pi_j(b) = 1 \end{cases} .$$

At state  $j$ , the sum of waiting time of seniors is given by:

$$\frac{1}{K(b)}[(j-1) + \dots + 1 + 0] = \frac{(j-1)j}{2K(b)} .$$

Hence, The expected total waiting time of the public system is given by:

$$w_{pu}(b) = \sum_{j=Q_1}^{Q_2} \frac{(j-1)j}{2K(b)} \pi_j(b) \quad (3)$$

The average waiting time per patient of the public system is given by:

$$\bar{w}_{pu}(b) \equiv \sum_{j=Q_1}^{Q_2} \frac{j}{K(b)} \pi_j(b) \quad (4)$$

For the shunting approach, the average number of seniors attending the package services is:

$$\sum_{j=Q_1}^{Q_2} E([\alpha(v)A(j)])\pi_j(b-mv). \text{ Each patient will get a voucher worth } v, \text{ and wait for } w_{pr}$$

time periods in the package services system. The remaining amount  $(b-mv)$  is invested in the public LTC system. Then, the total waiting time of the packages services system  $w'_{pu}(b-mv, v)$  can be obtained through the transition probability matrix:

$$\begin{cases} \pi(b-mv, v) = \pi(b-mv, v)T(b-mv, v) \\ \sum_j \pi_j(b-mv, v) = 1 \end{cases}$$

where  $\pi(b-mv, v)$  is the stationary distribution function, and  $T(b-mv, v)$  is the transition probability matrix [85].

### 5.1.2. Model Application

#### Parameters Definition

The described models contain complicated transition probability matrixes. Thus, it is difficult to find the optimal solution with a closed form formula. However, if we define parameters, the waiting time can be easily obtained. The models will be applied in a real life situation and the result will be analyzed. Our purpose is to compare the two approaches and provide useful advice for selecting an approach. We parameterized the models with statistics documents, figures, surveys and data from DHW, 2014, research results and many other government sources [33, 38, 86–97]

According to a survey and LTC system internal analysis, they indicated that approximately 25% (0.25) of LTC clients defer or refuse a bed offer [38, 84]. Thus, we will assume that these patients are looking for a different more convenient type of care like:

Package services from different providers (Example: either home care, community-based care-programs, private care facilities, individuals offering home care).

Moreover, The national average hourly rate for homemaker/companions is 19\$/hour, the recommended hours are: 4.55/day, the offered hours: 2.48/day. The paid hours: 5.99/day. So, we assume that the daily estimated voucher cost for a package services/senior is:  $19\$ \times ((4.55 + 2.48 + 5.9) / 3) \text{hours} = 19\$ \times 4.31 \text{hours} = 81.89\$ \approx 82\$$ . It is known that the public home care average cost in Nova Scotia is: 33\$/day. Thus:  $(82+33)/2 = 57.5\$/\text{day}/\text{patient} \approx 60\$$  would be the optimum cost. We conclude that if a senior has chosen private home care the average daily cost would be 82\$, however for the government to balance that price with the public cost, the cost would be: 58\$/day /patient.  $33\$ < 60\$ < 82\$$ , This means that the new daily voucher cost will be more than the daily public home care cost. However, it is a good policy to implement. Why? Even if that daily voucher cost is higher than the daily public home care' cost, it is certainly way cheaper than the daily ALC, or LTC cost. Thus, if more seniors (a high percentage) choose that option, the cost and the waiting time will be both reduced.

In other cases, the voucher value may increase because the patients may need extra level of care to be paid. For example a disable senior in need of physiotherapy twice a month will approximately cost:  $80 \times 2 = 160\$$ , thus, the voucher value may increase to:  $160/30 + 60 = 66\$/\text{day}$ . Thus,  $\alpha(60) = 0.25$  Minimum or  $\alpha(66) = 0.25$  Maximum. The value of the Max voucher 66 is actually lower than ALC and LTC daily costs. However, in cases where patients have complicated and extensive care needs, the voucher value may increase. Lets assume that the government will offer the vouchers to those patients who are in need of light level of care, and those with more complicated conditions will stay in the LTC public



care waiting list and be a priority. As a result, we choose the Min voucher 60\$/day and  $\alpha(60) = 0.25$

The government average daily costs for: home care/patient is: 104\$, LTC/patient is:  $178.1 + 300 + 500/2 = 325\$$  and ALC/ patient is: 500\$. As a result, the total final costs would be: The total cost – the accommodation fee. Accommodations fees are as follow:

HC  $((33+82)/2 = 60\$)$ ,

LTC  $((105+61+50)/3 = 72\$/\text{day}/\text{patient})$ ,

ALC  $((165+145)/2 = 155\$/\text{day}/\text{patient})$ ,

<b>ALC</b>	<b>500 – 155 = 350\$</b>
<b>LTC</b>	<b>325 – 72 = 254\$</b>
<b>HC</b>	<b>104 – 60 = 44\$</b>

The average annual doctor payment in Nova Scotia is: 250.000\$, works 8 hours/day (56 hours/week) and need around 2 hour a week to give recommendations. The average hourly payment for a LTC nurse is: 36\$/hour, gets paid for 6 hour/day (80.000\$ annually), and needs around 5 hours to care for a senior. The average length of stay in a LTC facility is: 3 years. We conclude that in order to increase one senior output from the system (LTC), the cost is represented as:

(Nurse cost + Doctor cost) in 3 years =

$$3\left(\left(250.000 \left(\frac{52 \times 2}{52 \times 56}\right)\right) + \left(80.000 \left(\frac{365 \times 5}{365 \times 6}\right)\right)\right) = 3(8928.57 \$ + 66666.66\$) = 3(75595.23\$) = 226785.69\$$$

This means that the annual cost for a senior output is  $\approx 75596\$$ , and because the average LOS for a senior in a nursing home is 3 years the total cost will be  $\approx 226786\$$ . Thus, the daily cost to get a patient out a LTC facility is  $\approx 207\$ \approx (178.1\$ - 300\$)$ : Average annual

LTC cost/patient according to the DHW, 2014). Let's put the average: 250\$ including other costs.

According to our data analysis (Chapter 4), the turnover rate for NHs and RCFs in Nova Scotia is represented in the table below:

Turnover rate NHs & RCFs	DHA1	DHA2	DHA3	DHA4	DHA5	DHA6	DHA7	DHA8	DHA9
FYTD 2011/12	0.4659	0.4718	0.4194	0.3344	0.4699	0.4306	0.4276	0.3438	0.3707
FYTD 2012/13	0.4567	0.4357	0.4181	0.3441	0.4241	0.4762	0.3684	0.3236	0.3656
FYTD 2013/14	0.3867	0.3824	0.4103	0.3635	0.4265	0.4008	0.3904	0.3266	0.3928

The average turnover rate for all the three years (2011-2014) is: 0.4008. This means that the average service rate in LTC facilities in Nova Scotia is: 0.4 senior/year (takes 2.5 years for a patient to leave the facility/year  $\approx$  3 years LOS according to [38]).

We know that the annual budget is 795\$ Million, our expanding approach budget (investment is:  $b$ ). Thus, we conclude that in our expanding approach the service rate is:

$$K(b) = 0.4 + \frac{b - 250 \times 0.4}{250} = 0.4 + \frac{b - 100}{250} \quad (5)$$

We obtain the upper bound and lower bound of the length of the queue from LTC queue changes (increase),  $Q_1 = 900$  and  $Q_2 = 2575$ . Nova Scotia's government is actually budgeting the entire continuing care system around 795\$ M/year (560.1\$ for LTC and 234.9\$ M for HC and CC). According to the baby boom generation dilemma, Nova Scotia's seniors (65+) will still be increasing until year (2025-2036). Thus, let's assume that Nova Scotia's government will provide an extra 200\$ M/year (200\$ M + 560.1\$ M = 760.1\$ M) to launch the voucher scheme. The scheme will last 10 years (2015-2025), and the waiting list increases by approximately 200 senior/year; thus, the number of elderly persons who are eligible for the vouchers in 2015, 2016, ... until 2025 will be approximately 2.600, 2.800,

... until 4.600, respectively. Assume that a senior in a LTC facility stays that all year long (365 days), about 90% of seniors in the waiting list are interested in having a facility bed offer.

According to the DHW (2013), approximately 2,400 Nova Scotia's seniors were waiting for a placement into a LTC facility, and 2,100 (87.5%) of these individuals were waiting at home, and only 57%, of those seniors waiting at home were accessing provincial home care services. Thus, 12.5% seniors are waiting in a hospital, and 43% of seniors waiting at home are not offered Home care.

There are a total of 155 (87+37+31) LTC facilities in NS, and 7821beds, As it is known, once a senior is admitted to a LTC facility, he/she is taken care of 24/7, so we assume 365 (1 year) working days per year. Also, LTC are working at almost all their full capacity (90-99%). The LOS is: (2.5 or 3) years/senior, and turnover rate is between: (0.3 and 0.4) patient/year. Thus the average number of seniors attending public LTC service per year is:  $155 \times (0.33 \text{ or } 0.4) \approx 155/(2.5 \text{ or } 3) \text{ years} \approx (52 \text{ or } 62) \approx 56 \text{ seniors/year}$ .

Since  $\alpha(60) = 0.25$ , among 56 patients, 15 patients on average will go to the private package services. Thus  $m=15$  and corresponding the total value of voucher is:  $mv = 60 \times 15 = 900\$$  for each period. The number of patients using vouchers in each period may vary, so we use average budget in the public LTC service, which is  $(b - 900)$  for each period. Thus, in the shunting approach, the departure rate of the public LTC system is given by:

$$K(b - mv) = 0.4 + \left[ \frac{b - 900 - 100}{250} \right] \quad (6)$$

Parameters		Value (Nova Scotia)
% LTC Bed Refusal (Prefer HC or CC Program)		25% of Total LTC Waiting List
Canadian Doctor Average Annual Salary		\$307,000 / Year
Nova Scotia Doctor Average Annual Salary		\$250,000 / Year
Public Care NH Daily Accommodation Cost		105\$ / Day
Private Care NH Daily Cost (Private Room)		(\$258 Daily / \$94,170 Annually)
Private Care NH Daily Cost (Semi Private Room)		(\$227 Daily / \$82,855 Annually)
Registered Nurse Hourly Salary (Acute Care)		35.2\$ / Hour
Registered Nurse Hourly Salary (LTC)		32\$ Min - 40\$ max / Hour
Registered Nurse hourly Salary (Continuing Care)		25\$ Min - 32\$ Max / Hour
Recommended Hours for Daily LTC Care		4.55 Hours / Resident Day
Nova Scotia Averaged LTC Services Paid Hours		5.9 Paid Hours / Resident Day
Nova Scotia LTC Provided Hours		2.48 Hours / Resident Day
LTC Length of Stay (LOS)		2.5 - 3 years Average
Nova Scotia's Beds Occupancy Rate		96.6%
# Nursing Homes (NS)		87 facilities (6713-6902 Beds)
# Residential Care Facilities (NS)		37 facilities (820-931 Beds)
# Community Based Options (NS)		31 facilities (90 Beds)
Parameters	Value (Ontario)	Value (Nova Scotia)
Hospital Bed Daily Cost. Gov	842\$ / Day / Patient	500\$ / Day / Patient (Goes up to 1000\$)
LTC Daily Costs. Gov	126\$ / Day / Patient	178.1\$ - 300\$ / Day / Patient (Goes up to 500\$)
Home Care Daily Cost. Gov	42\$ / Day / Patient	103 - 105\$ / Day / Patient
Hospital Bed Cost (Patient Accommodation Rate)		165\$ / Day (Private) 145\$ / Day (Semi-private) Ward (Free/MSI)
LTC Bed Cost (Patient Accommodation Rate)	56.93 \$ / Day / Patient	105\$ / Day / Patient (NH) 61\$ / Day / Patient (RCF) 50\$ / Day / Patient (CBO)
Home Care Cost (Patient Accommodation Rate)	19\$ / Hour	15\$ Min - 25\$ Max / Hour Average (\$19 /Hour) 33\$ - 50\$ / Day

**Table 5.1:** Method I parameters definitions I

Source: [8, 19, 25, 26, 28, 29, 30, 33, 38, 86–99]

<b>Define Q1, Q2</b>	
<b>Parameters</b>	<b>Value (Nova Scotia)</b>
<b>LTC Waiting List 2006</b>	<b>900</b>
<b>LTC Waiting List 2007</b>	<b>1,284</b>
<b>LTC Waiting List 2010</b>	<b>1,740</b>
<b>LTC Waiting List 2012-2013</b>	<b>2,400</b>
<b>LTC Waiting List 2013</b>	<b>2,551</b>
<b>LTC Waiting List 2014</b>	<b>2,575 and (837 Pending in approval process)</b>
<b>ALC Waiting List 2014</b>	<b>86 and (12 Pending in approval process)</b>
<b>Define Budget &amp; Voucher Cost</b>	
<b>Parameters</b>	<b>Value (Nova Scotia)</b>
<b>Continuing Care Annual Budget</b>	<b>\$795 Million</b>
<b>LTC Annual Budget</b>	<b>\$560.1 Million</b>
<b>Home Care &amp; Community Care Annual Budget</b>	<b>\$234.9 Million</b>
<b>Home Care Annual Budget</b>	<b>\$196 Million</b>
<b>LTC Total Provincial Cost</b>	<b>\$669 Million</b> <b>(\$538 from province, rest from residents)</b>

**Table 5.2:** Method I Parameters Definitions II

Source: [6, 8, 9, 11, 38, 86, 100]

### 5.1.3. Simulation Results

At the beginning of the experiment, we randomly generate one transition probability matrix by the basic setting,  $b = 4000$  and  $v = 0$ . The maximum of  $A(s)$  is set to 50. We increase  $b$  from 4000\$ to 10,000\$, at a constant increase interval of 1000\$ and evaluate the waiting time.

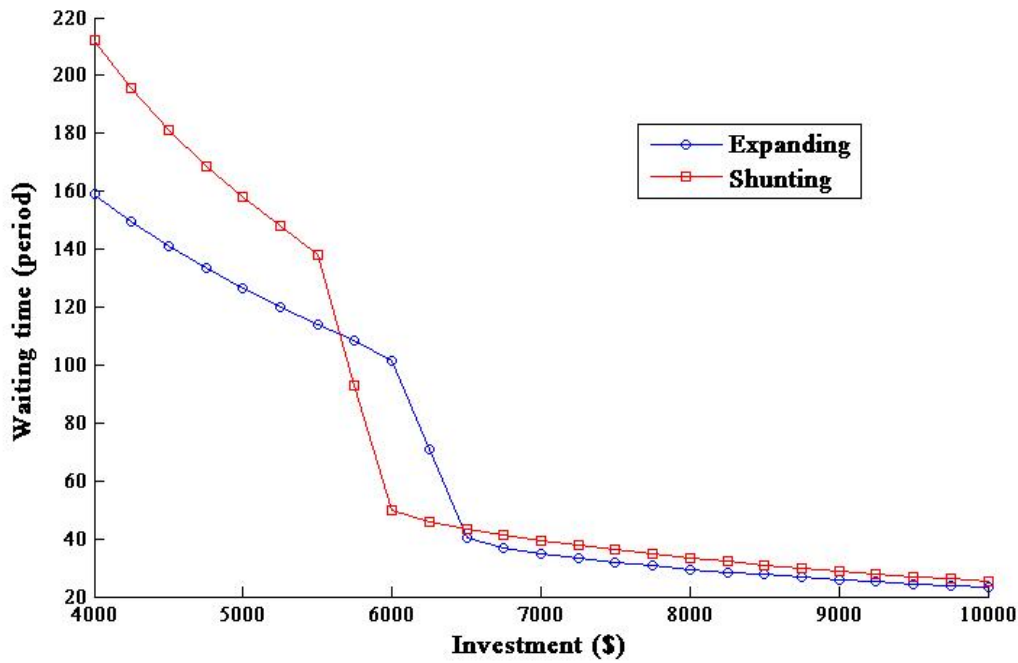

**Figure 5.2:** The average waiting time of case  $(\alpha(60), 900, 2575)$

Figure 5.2: shows that the dominant approach can be either one. First is the expanding approach, followed by the shunting approach as the investment increases.

We conclude that there are two special points in the results, denote them as  $i = A, B$ . Let  $x_i$  represent the investment  $b$  associated with point  $i$ . Then  $x_A = 5700$ ,  $x_B = 6500$ . The figure can be divided into three sections. Before point A, the shunting curve is above the expanding curve, showing that when investment  $b < x_A$ , the performance of the expanding approach is better than the shunting approach. As the investment increases to interval  $(x_A, x_B)$ , the shunting curve drops below the expanding curve, meaning that the performance of the expanding approach is worse than the shunting approach. If investment  $b > x_B$ , the two curves converge, indicating that these approaches have similar performance, while the expanding approach is still slightly better.

Moreover, the changes of the decreasing rate of the average waiting time with investment in the three sections. When  $b < x_A$ , the shunting approach reduces waiting time faster than the expanding approach. When  $x_A < b < x_B$ , the two approaches have a close decreasing rate. Finally, when  $b > x_B$ , both approaches have low decreasing rate and the average time almost remains unchanged.

This phenomenon can be explained as follows. In the beginning, since there are a lot of patients and long waiting time, the expanding approach has more obvious effect than the shunting approach. However, in the shunting approach, since 25% of the patients go to private services, the remaining investment ( $b - mv$ ) in the public system will have greater impact on the performance, resulting in a faster decreasing rate, as in the third section of the expanding approach. In other words, although the shunting approach starts with worse waiting time, it decreases waiting time faster than the expanding approach. Due to the fast decreasing rate, the shunting approach catches up with the expanding approach and becomes better than the expanding approach in the second section.

Based on the above observation, some useful insights are obtained. If the government invest a small budget,  $b < x_A$ , the expanding approach should be adopted. If investment  $x_B < b < x_B$ , the shunting approach should be adopted. It is not worthwhile to add investment beyond  $x_B$  since the waiting time will not be reduced much.

#### **5.1.4. Study of Different Scenarios**

In this section, we investigate how the performance of the two approaches with some parameters changes. First, we examine the impact of different  $\alpha(v)$  value on the waiting time. Currently  $\alpha(60) = 0.25$ , which means only 25% of patients go to the private service.

Obviously if the value increases, more patients would choose private services. Thus, we will examine the performance of the system with different voucher values.

Let's assume:  $\alpha(40) = 0.1$  and  $\alpha(120) = 0.4$ .

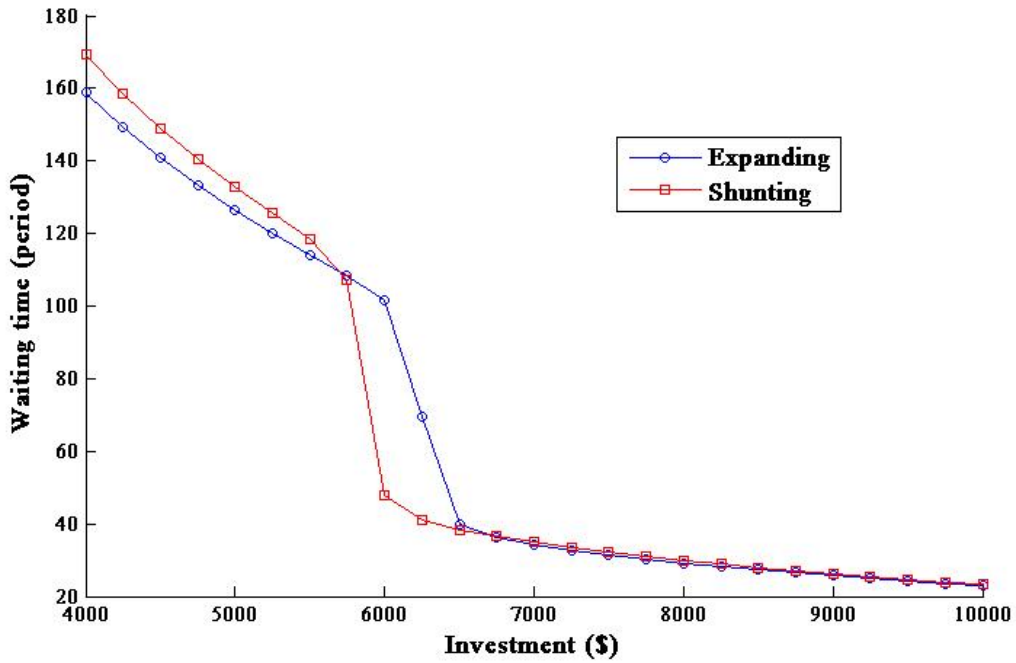

**Figure 5.3:** The average waiting time for case  $(\alpha(40), 900, 2575)$

Figure 5.3: shows the average waiting time of case  $(\alpha(40), 900, 2575)$ . We see that the results are quit similar to the previous case; the expanding approach has the same results, and the differences are in the lower waiting time for the shunting approach when  $b < x_A$ .



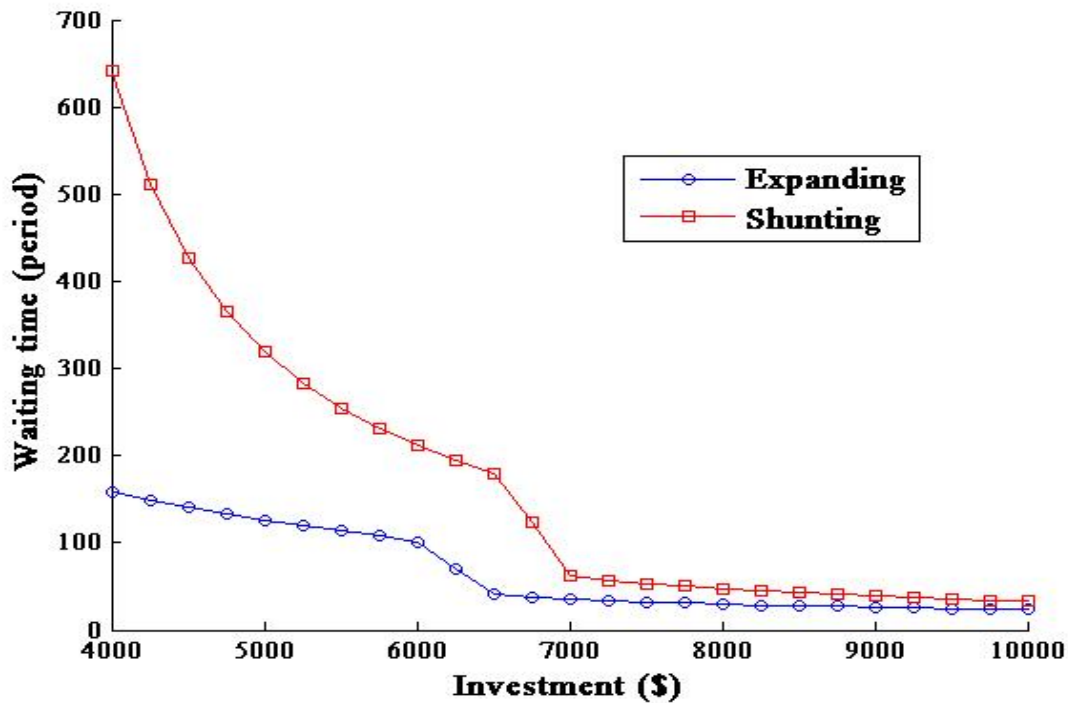

**Figure 5.4:** The average waiting time for case  $(\alpha(120),900,2575)$

Figure 5.4: depicts the average waiting time of case  $(\alpha(120),900,2575)$ . The shunting curve is always above the expanding curve. The expanding approach gives the same performance as the previous cases. The shunting approach when  $b < x_A$  gives a very high waiting time with a fast decreasing rate

In general, the shunting approach with high voucher value ( $v = 120$ ) is always worse than the expanding approach. For middle level voucher value ( $v = 60$ ), the shunting approach can be better than the expanding approach when the total investment is larger than threshold value \$5700. If investment is larger than \$6500, both approaches have similar performance. If the voucher value is low ( $v = 40$ ), the results are similar to the case where ( $v = 60$ ), and the difference is that the shunting approach waiting time is very high before the investment reaches 5700\$.

Tests were done among shunting approaches when  $Q_1 = 700$ , and  $Q_2 = 4000$  with different voucher values:  $(\alpha(40), 700_1, 4000)$ ,  $(\alpha(60), 700_1, 4000)$ ,  $(\alpha(120), 700_1, 4000)$ , the results were similar to the above tests:  $(\alpha(40), 900_1, 2575)$ ,  $(\alpha(60), 900_1, 2575)$ ,  $(\alpha(120), 900_1, 2575)$  in order.

## 5.2. Method II: Using Queuing Models

The steps that we will pursue in this method would be resumed as follows:

1. Apply both M/M/1 and M/M/s models on one nursing home case by using both M/M/s model assumptions and our actual case assumptions.
2. Do a scenario analysis of the different mentioned models above using an Excel Simulation for the M/M/s model.
3. Include a cost model to solve out waiting time and resource allocation challenge.

Using the model (M/M/1/ $\infty$ /FCFS), we will address the waiting queue problem, where we have only one nursing home to be considered our only server. The general model parameters are the M/M/1 model parameters with our assumptions. We won't look at the number of beds as servers, however that can be implemented if we consider a M/M/s model where the beds in a nursing home are our servers.

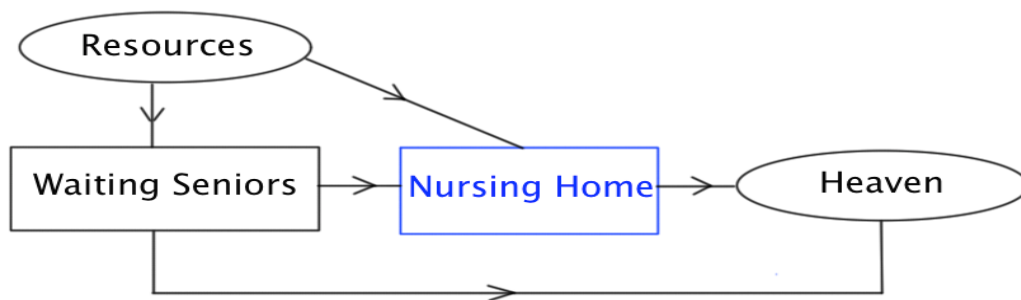

**Figure 5.5:** Method II: One Nursing Home Queuing model

### 5.2.1. Assumptions

The following assumptions were set for queuing system analyzing long term care (One nursing home) waiting time and service costs, which is in accordance with the queuing theory [101]:

1. Arrivals follow a Poisson probability distribution at an average rate of  $\lambda$  patients (seniors) per unit of time.
2. The queue discipline is First-Come, First-Served (FCFS) basis by any of the servers. There is no priority classification for any arrival, no balking, jockeying blocking or reneging is considered.
3. Service times are distributed exponentially, with an average of  $\mu$  patients per unit of time.
4. There is no limit to the number of the queue (infinite).
5. The service provider (1/s nursing home(s)) (is/are) working at (its/their) full capacity.
6. The average service rate is greater than average arrival rate:  $s\mu > \lambda$ , ( $\lambda/s\mu < 1$ ).
7. Server here represents only (one/many) nursing home(s), but not other long-term care facilities.
8. Service rate is independent of the line length; service providers do not go faster because the line is longer.

9. The used formulas for M/M/1 model are shown below [101, 102].

### **M/M/1 model**

$\lambda$  = mean number of arrivals per time period

$\mu$  = mean number of people or items served per time period

$L$  = average number of units (customers) in the system (waiting and being served)

$$L = \frac{\lambda}{\mu - \lambda}$$

$W$  = average time a unit spends in the system (waiting time plus service time)

$$W = \frac{1}{\mu - \lambda}$$

$L_q$  = average number of units waiting in the queue

$$L_q = \frac{\lambda^2}{\mu(\mu - \lambda)}$$

$\rho$  = utilization factor for the system

$$\rho = \frac{\lambda}{\mu}$$

$P_0$  = probability of 0 units in the system (that is, the service unit is idle)

$$P_0 = 1 - \frac{\lambda}{\mu}$$

$P_{n>k}$  = probability of more than  $k$  units in the system, where  $n$  is the number of units in the system

$$P_{n>k} = \left( \frac{\lambda}{\mu} \right)^{k+1}$$

10. The used formulas for M/M/s model are shown below [102, 103].

**M/M/s model**

$s$  = number of channels open  
 $\lambda$  = average arrival rate  
 $\mu$  = average service rate at each channel

The probability that there are zero people or units in the system is

$$P_0 = \frac{1}{\left[ \sum_{n=0}^{s-1} \frac{1}{n!} \left( \frac{\lambda}{\mu} \right)^n \right] + \frac{1}{s!} \left( \frac{\lambda}{\mu} \right)^s \frac{s\mu}{s\mu - \lambda}}, \text{ for } s\mu > \lambda$$

The average number of people or units in the system is

$$L = \frac{\lambda\mu(\lambda/\mu)^s}{(s-1)!(s\mu - \lambda)^2} P_0 + \frac{\lambda}{\mu}$$

The average time a unit spends in the waiting line and being serviced (namely, in the system) is

$$W = \frac{\mu(\lambda/\mu)^s}{(s-1)!(s\mu - \lambda)^2} P_0 + \frac{1}{\mu} = \frac{L}{\lambda}$$

The average number of people or units in line waiting for service is

$$L_q = L - \frac{\lambda}{\mu}$$

The average time a person or unit spends in the queue waiting for service is

$$W_q = W - \frac{1}{\mu} = \frac{L_q}{\lambda}$$

### 5.2.2. Scenario Analysis

A scenario analysis is done for the proposed model above, here it is presented:

#### Base Case Scenario

As we know from the literature, currently there are 2,400 seniors waiting for LTC in Nova Scotia [49]. However, in this case we are addressing the waiting queue of only one nursing home and not the entire LTC system. Lets assume in our base case scenario we are using an M/M/1 model, we have only one nursing home, where:  $N(t)$  is the number of

seniors in the nursing home and its queue at time  $t$ .  $N(t)$  is a Birth & Death Process with constant arrival rate  $\lambda = 2$  senior/month, and constant service rate  $\mu = 3$  years/senior.

This case can't be solved with an M/M/1 model, but possible with a M/M/s model. Why? Because assuming that our nursing home will be available if a bed is available can't be understood by our simulation. Thus, we have to consider the bedding number as servers to be able to address the problem.

The simulation didn't run those parameters because the waiting line is too long (arrival rate  $>$  than service rate). We did calculate the results manually, as it can be seen; the results are negative showing that the system is not stable.

**Analysis: (M/M/1 model)**

$$\lambda = 2 \text{ senior/month} = 24 \text{ senior/year}$$

$$W_s = 3 \text{ years} = 36 \text{ months}$$

$$\text{Service waiting time: } W_s = 1/\mu \Rightarrow \mu = 1/W_s = 1/3 = 0.33 \text{ senior/year or } 0.0275 \text{ senior/month}$$

$$\text{System Utilization: } p = \lambda/\mu = 2/0.0275 = 72.7272 = 7272.72\% \text{ nursing home is busy}$$

$$\text{The number of seniors in the system} = L = L_s + L_q = \lambda W = E[N(t)] = \frac{\lambda}{\mu - \lambda} = \frac{p}{1 - p} = -1.014$$

$$\text{The number of seniors in the service} = L_s = \lambda W_s$$

$$\text{The number of seniors in the waiting queue} = L_q = \lambda W_q$$

By Little's law  $L = \lambda W$ , we know that the average time a customer spends in the system is:

$$W = L/\lambda = \frac{1}{\mu - \lambda} = -0.507 \text{ months.}$$

$$W = W_s + W_q \Rightarrow \text{Time waiting in queue: } W_q = W - W_s = -0.507 - 36 = -36.507 \text{ months}$$

$$\text{Thus, The number of seniors in the waiting queue: } L_q = \lambda W_q = 2 * (-36.507) = -73.014$$

Here are the simulation results:

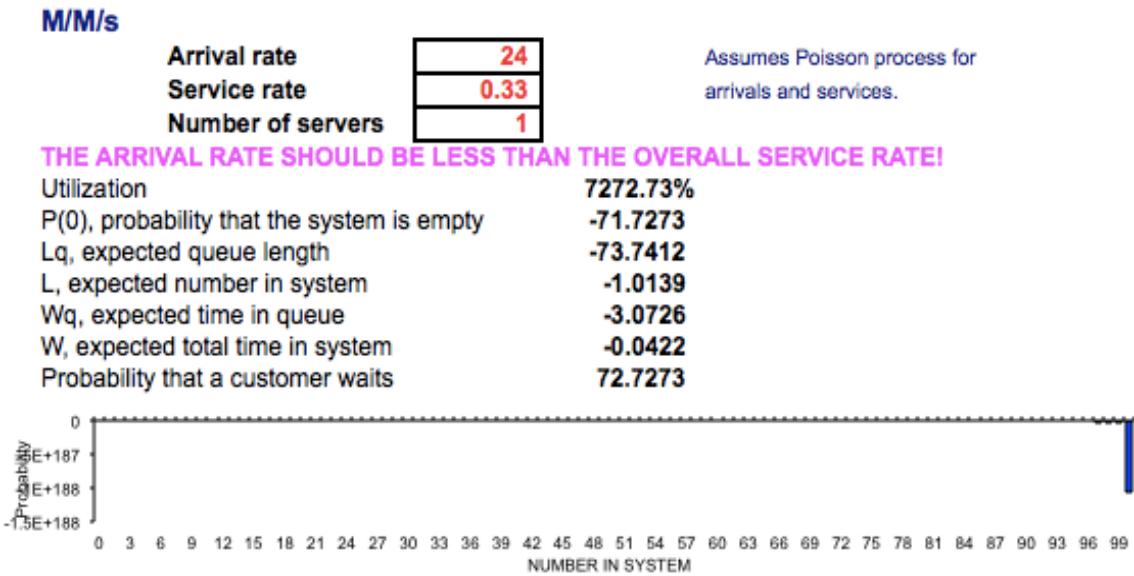

**Figure 5.7:** Scenario analysis results, base case scenario 1

As we can see the M/M/1 model doesn't represent our real case nursing home, where the number of bedding is considered the servers instead of the nursing home itself. We will use M/M/s model in this case. Let's assume that in our nursing home we have  $s = 60$  beds available as a base case, the results are:

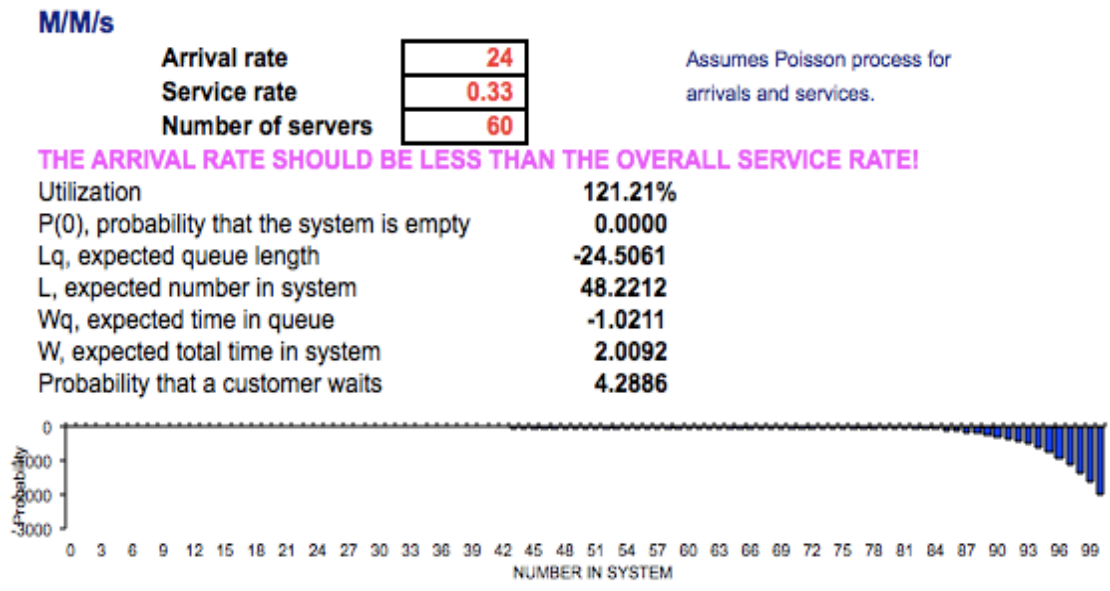
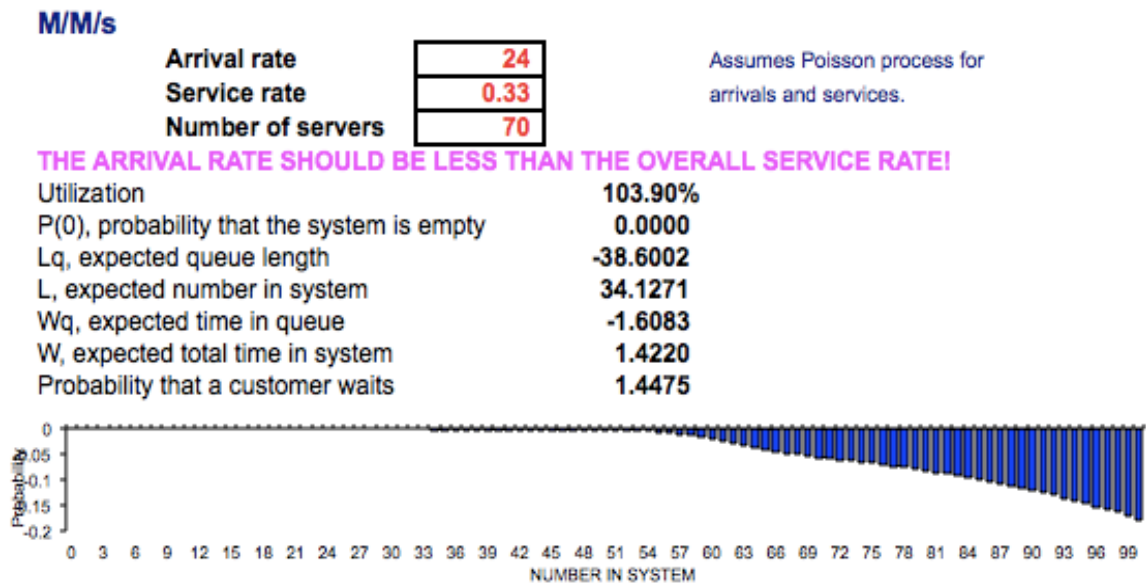

**Figure 5.8:** Scenario analysis results, base case scenario 2

The system is showing instability, it doesn't satisfy the condition:  $\mu > \lambda$ , we either increase bedding or decrease arrival rate to have some stability.

### Change in (Capacity/Serving Rate) Scenario

One possible option for reducing the number of seniors waiting in the queue is increasing the model's capacity (the number of available beds in the nursing home, may be staffing...etc). In this case, let's change the nursing home bedding capacity (since we're addressing a one nursing home case, we can set the increase at 10 beds/nursing home (60+10=70beds). This will result in a quicker overall serving rate/not service rate (as it will be the same in this case), the more the seniors are served, the less other seniors in the queue will wait. While arrival rate and other parameters value are kept in the base case.



**Figure 5.9:** Scenario analysis results, capacity/serving rate change scenario 1

As we can see, the queue waiting time and length decreased, however not to an optimum level where the system is stable, this means we either increase the bedding or the arrival rate to get the optimum.



Increasing the nursing home capacity can reduce the number of waiting patients in the queue. However, the effects of adding a certain number of beds (10 beds) to the nursing home, doesn't necessary ensure that the waiting queue and time problem is completely solved. In other words, it indicates that for reducing number of waiting patients significantly, there is a minimum number of additional beds need to be added to the nursing home capacity (needs to be proven with the condition:  $s\mu > \lambda = 0.33s > 24 \Rightarrow s=73$  minimum).

After many tries we ended up with the fact that we should have, 75 beds available/nursing home to address that arrival rate of 24 seniors/year and a senior service time of 3 years. The system now is showing some stability, where the system utilization is 96.97%. The results as shown below:

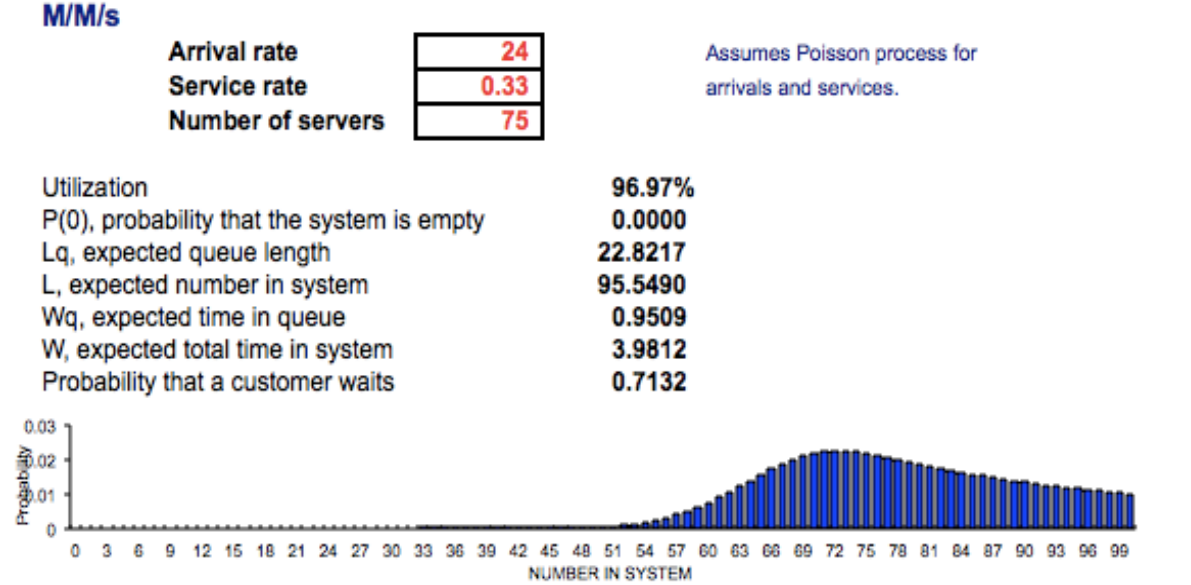

**Figure 5.10:** Scenario analysis results, capacity/serving rate change scenario 2

Increasing capacity may not be the ultimate solution, as Nova Scotia's government is not willing to increase nursing homes capacities, but investing in a more oriented home care solution instead.

Moreover, this policy can be one of the possible solutions for the waiting time challenge, but it is not the optimal one because one large concern is that the introduction of additional beds may cause demand to increase as wait times are known to act as a deterrent to demand. Also, increasing capacity will result in an increase of service costs, thus the overall costs. The improvement with certain number of additional beds might be considered in the future policy recommendations.

### **Change in Arrival rate/Demand Scenario**

As we know arrival rate/patient flow is an important parameter in any queuing model. We mentioned in our introduction that the number of seniors in Nova Scotia is expected to increase in the upcoming years (till 2025...), thus it is reasonable to assume that aging population will impact seniors flow.

The effect of increasing demand on performance of the model might be more influential in real cases. The main effect of the arrival rate growth is an increase in the number of seniors in the model (more than the base case scenario) and the number of patients in the waiting list because of the lack of a vacant bed downstream increases (more than the base case scenario).

Let's assume that the arrival rate increases to 3 seniors/month (36 seniors/year) instead of two. Other system parameters are kept the same: 75 beds (servers), service rate are the same. The results are:

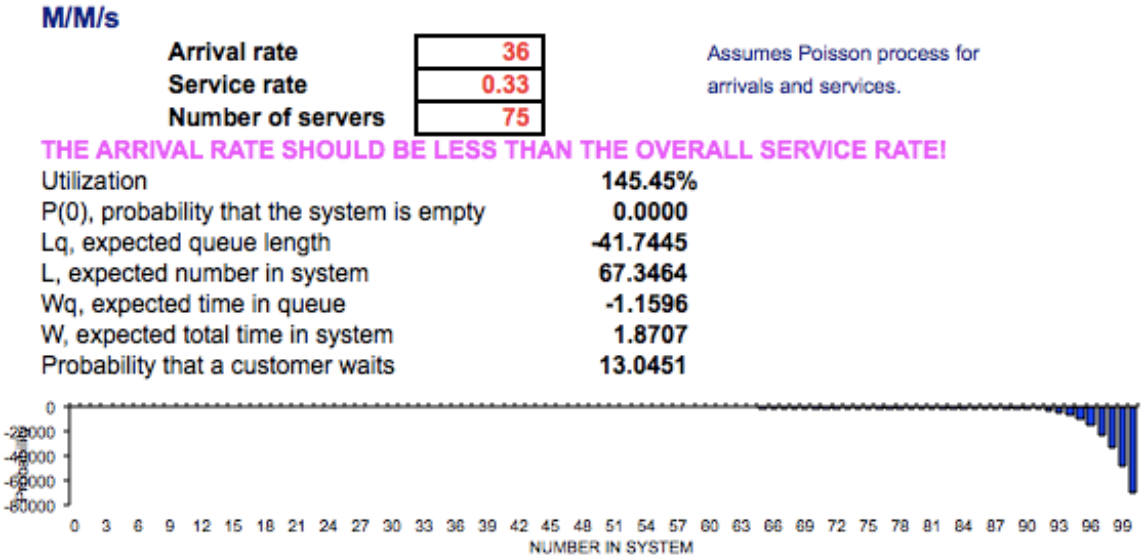

**Figure 5.11:** Scenario analysis results, arrival rate/demand change scenario

As we can see, the system went to a worse case of instability where the queue length and waiting time skyrockets, and the condition:  $s\mu > \lambda = 0.33s > 36 \Rightarrow s=110$  minimum is not satisfied. To regain system's stability, we have to increase the bedding to no less than: 110 beds. This is not possible as it would be very costly for the government to provide a very high bedding number. Especially that the senior's number is increasing (2012-2025-2031) and will be decreasing after 2031. This means that if the capacity (beds) is increased it will be of no use after 2031 (idle system).

The M/M/s parameters are highly sensitive to the seniors' arrival rate. Considering that in the coming years patient flow is expected to increase, developing the appropriate strategies (increase in capacity and offer alternate service institution) is critical.

**Mixed Policy Scenario**

This scenario shows the effect of changing more than one parameter on the model performance. One possible scenario that can help to reduce the waiting time and seniors' number in queue is to increase capacity (serving rate) and decrease demand (arrival rate)

either in a temporary or a permanent way. How? Increase the M/M/s model capacity by adding a significant, sufficient beds and care requirements. Also, decreasing the demand or arrival rate of our nursing home by sending our waiting seniors to other nursing homes, ALC, or homecare; and that can be temporarily until a bed is available in our nursing home, or permanently if the provided care is what that the senior really need. In this case, we will end up by having either a M/M/s model for more than one nursing home or a queuing network to model this situation (our next model).

Let's assume that the demand decreased and we have an arrival rate of: 1 senior/month (12 seniors/year). We also assumed that the bedding capacity is 75 beds. The results are:

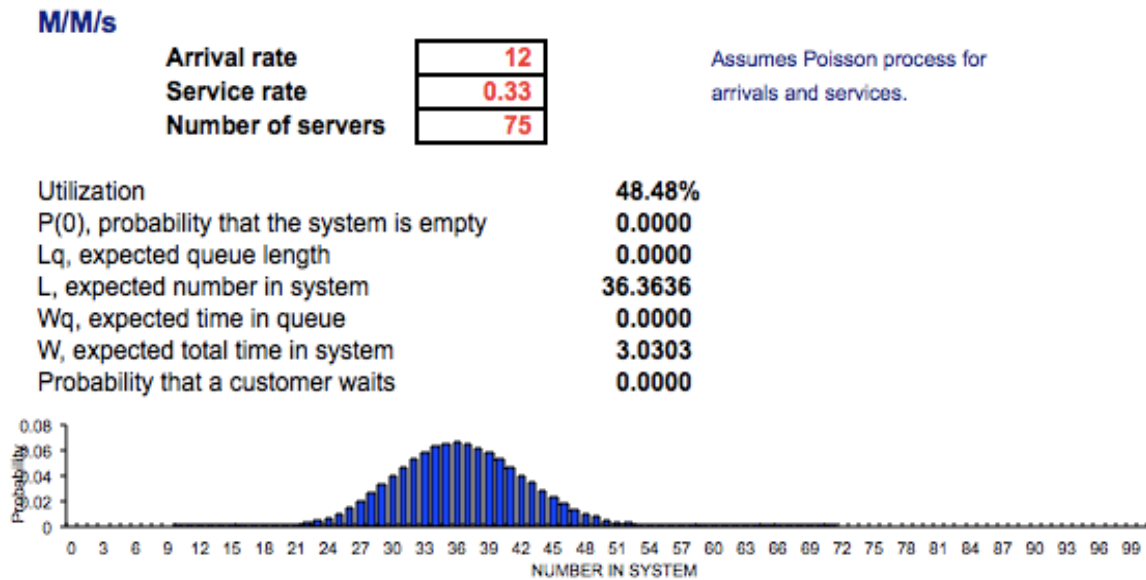

**Figure 5.12:** Scenario analysis results, mixed policy scenario 1

As it is shown, the service time is 3 years, no waiting time or seniors waiting. However, the system utilization is only: 48.48%, which means almost more than half of the beds are idle, this will increase capacity cost. Thus, there is no need for increase in bedding if demand decreases. The required solution is an acceptable decrease in demand (for

example decreasing nursing homes demand by offering home care to a level where the nursing homes are neither saturated nor idle), or decrease in bedding capacity so the overall system cost will decrease (this option is not realistic). According to our simulation the optimum bedding requirement when the arrival rate decreases to 1 senior/month is: 40 beds, the extra beds might be used as acute care beds occasionally by ALC. Here are the results:

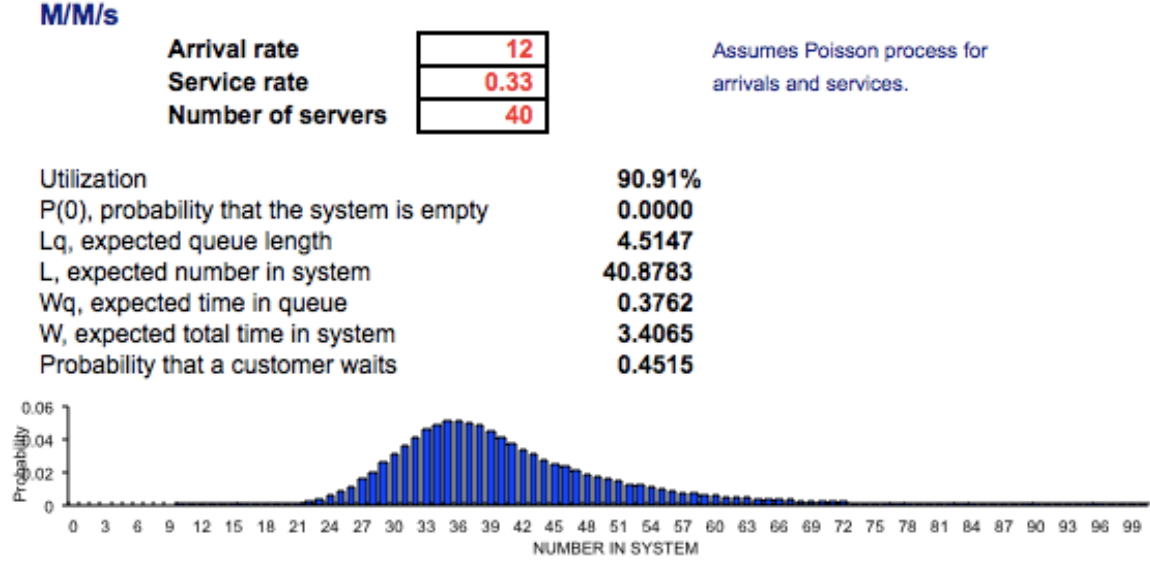

**Figure 5.13:** Scenario analysis results, mixed policy scenario 2

The results show a balanced system where the service time is 3 years/senior. Waiting time in queue is: 3 months<the actual average waiting time, 6 months waiting (reduced by half). The system utilization is: 90.91% (serving 40 patients, while only: 4 patients are in the waiting list).

The direct result of this policy is a reduction in the demand for our only nursing home from acute care and seniors at home. The seniors’ shorter stay in a nursing home (after being served in homecare or ALC) will decrease waiting time, waiting line length, and service time, but increase service rate. To implement such a policy, increasing the capacity of homecare service is required. Since the average cost of homecare service per senior is

way less than an ALC or nursing home bed, this policy might save a substantial amount of money for health care system.

The money spent to increase the bedding capacity to accommodate the increasing arrival rate, should be used to support homecare as an alternative for those who qualified for. 50% of seniors will be affiliated to homecare, and the rest will benefit from nursing homes, as the demand will decrease for. Thus, a balanced senior care system

### Analysis Conclusion

As it is shown in previous results, the system is very sensitive to its parameters (arrival rate, number of servers, service rate (fixed in our case)). If we leave the system at its original state, the optimum solution would be a slight increase in beds ( $75+5=80$ beds), and try to decrease the arrival rate by implementing a sophisticated homecare program. In case if any beds become vacant, they can be used as temporary ALC beds. Shown below:

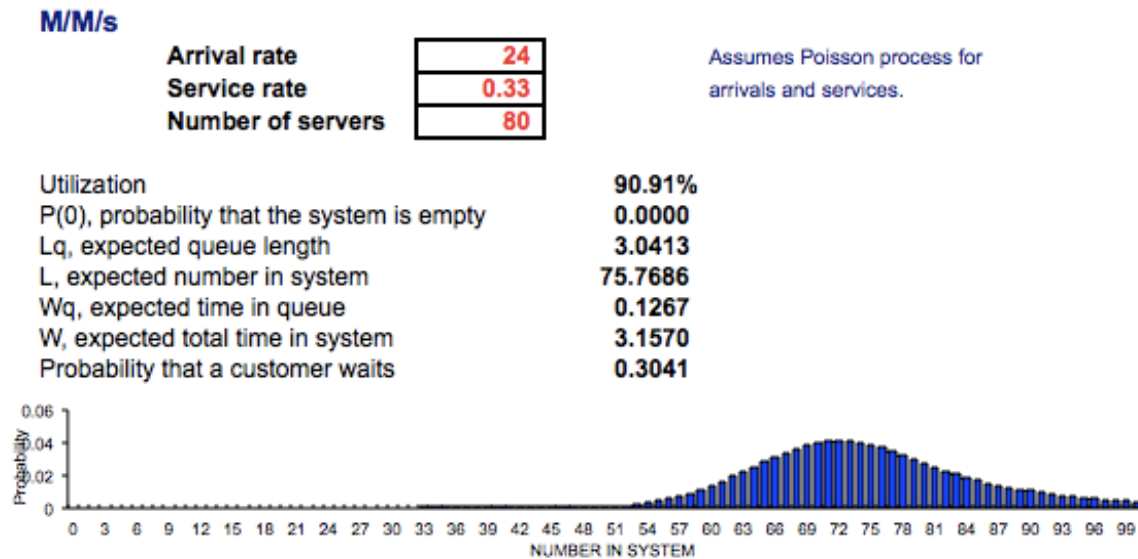

**Figure 5.14:** Scenario analysis conclusion

### 5.3. Cost Model

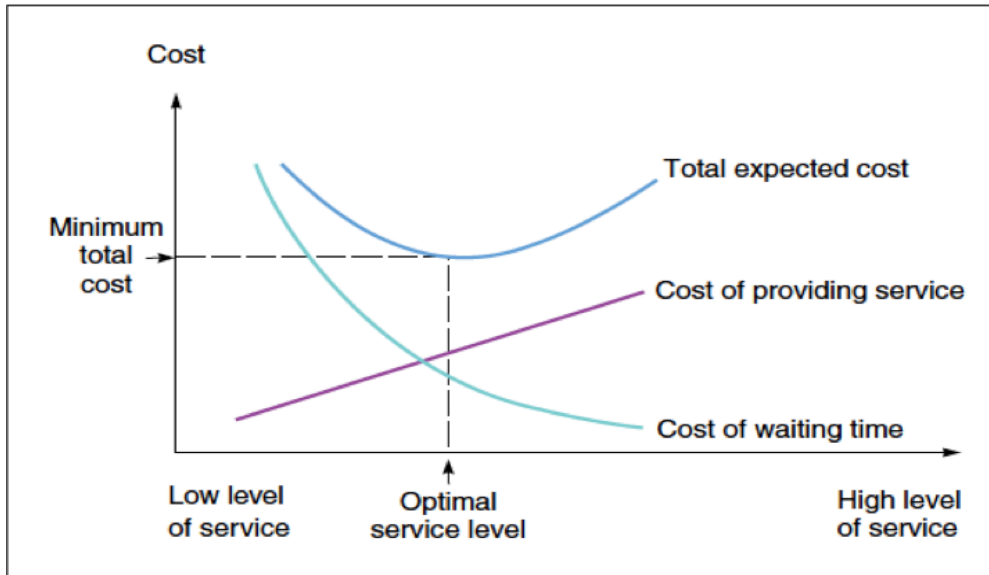

**Figure 5.15:** Queuing healthcare system associated waiting and capacity costs [100]

If we know the exact costs associated with the system  $C_s$  and  $C_w$ , like waiting cost and service cost (which we do: 33\$/day for homecare and 50\$-300\$ for LTC), we can use the formulas below to calculate the M/M/s model costs [101, 102].

**Cost model**

Expected Service Costs in the System =  $E(SC) = sC_s$

$s$  = number of servers  
 $C_s$  = service cost of each server

Expected Waiting Costs in the System =  $E(WC) = (\lambda W)C_w$

$\lambda$  = number of arrivals  
 $W$  = Average time an arrival spends in the system  
 $C_w$  = Opportunity cost of waiting by patients

Expected Total Costs  $E(TC) = E(SC) + E(WC)$

Expected Total Costs  $E(TC) = sC_s + (\lambda W)C_w = sC_s + (L)C_w$

Goal: Minimize  $(TC) = sC_s + LC_w$

In our basic case scenario: we suppose we have one nursing home in Nova Scotia, with  $s$  servers (beds). We know that the daily service cost ( $C_s$ ) for a nursing home is around: 300\$. Assume arrival rate is: 2 seniors/month (24 seniors/year, 2 senior/month, 0.066 seniors/day). Service rate is: 1 senior/3 years (0.33 senior/year, 0.0275 senior/month, 0.00091 senior/day).

$\lambda$	$\mu = 1/W_s$
24/year	0.33/year
2/month	0.0275/month
0.066/day	0.00091/day

$W_s = 3$  years/senior.  $C_w = 500$ \$, because if a patient is in ALC waiting to be accepted in a nursing home, the daily cost is: 500\$/day. Similarly, if a patient is waiting at home getting home care, the daily cost is: 105\$ + injury risk (that would put him/her in a hospital). Thus, we would either address at the case of ALC and community costs separately or just consider the waiting cost about: 500\$/day. The usual waiting time for a bed in a LTC facility in Nova Scotia varies between 86 and 238 days [7]. Moreover, according to [33, 88] the average waiting time in waiting list is: 214 days. Thus,  $W = W_s + W_q = 3$  years + 214 days = 1309 days = 44 months = 3.5 years.

Minimize ( $TC$ ) = Minimize ( $sC_s + LC_w$ ) = Minimize ( $300s + 500L$ ).

The condition:  $s\mu > \lambda$ , ( $\lambda/s\mu < 1$ ) has to be true before any testing:



## M/M/s Model Test

The only changing parameter is: $s$ (number of servers (beds))									
Basic scenario: $\lambda = 2$ seniors/month, $\mu = 1$ senior/3 years (0.33 senior/year) Condition: $s\mu > \lambda = 0.33s > 24 \Rightarrow s = 73$ beds minimum									
Case	$s$	$C_s$ / Day	$\lambda$	$\mu = 1/W_s$	$W = W_s + W_q$	$L = \lambda W$	$C_w$ / Day	Utilization = $\lambda/s\mu$	Total Cost/ Day
1	74	300\$	24/year	0.33/year	5 years	120.18	500\$	98.28%	82200\$/day
2	75	300\$	24/year	0.33/year	3.98 years	95.55	500\$	96.87%	70275\$/day
3	78	300\$	24/year	0.33/year	3.28 years	78.74	500\$	93.24%	62770\$/day
4	80	300\$	24/year	0.33/year	3.16 years	75.77	500\$	90.91%	61885\$/day
5	85	300\$	24/year	0.33/year	3.05 years	73.37	500\$	85.56%	62185\$/day
6	90	300\$	24/year	0.33/year	3.03 years	72.86	500\$	80.81%	63430\$/day
7	95	300\$	24/year	0.33/year	3.03 years	72.75	500\$	76.56%	64875\$/day
8	100	300\$	24/year	0.33/year	3.03 years	72.73	500\$	72.73%	66365\$/day

Table 5.3: M/M/s cost model results

The results are represented in the figure below:

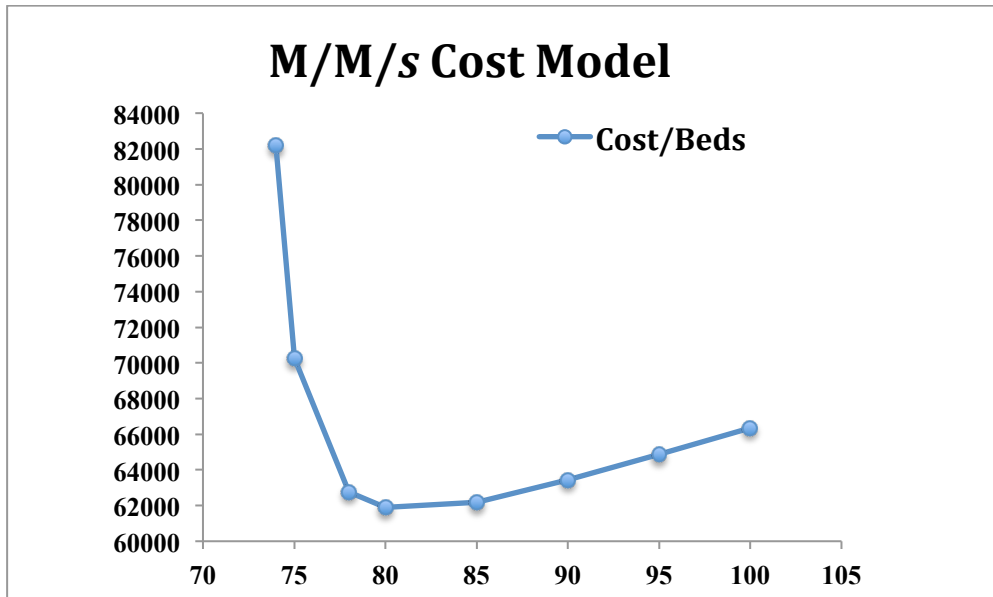

Figure 5.16: M/M/s cost model results

From the results, the more we increase the bedding number (>than the beds number needed for system stability (>73)), the less is the total daily cost for 1 nursing home. However, the more beds are available, the less utilization (vacant beds). This means, that first: waiting costs are the cause for high total costs. After reaching an optimum bedding number (at: 80 beds), an increase in bedding causes an increase in service costs resulting in high total costs. This means that if the arrival rate and service rate are known and fixed. There has to be a specific bedding number that keeps the system working at its full and lower cost capacity. In this case,  $s = 80$  is the optimum as it will give the highest system utilization, lowest costs and convenient (waiting, service, system) time: 3.16 years= 3 years service time + 2 months queue waiting time.

**M/D/s Model Test:**  $W = \text{Constant} = W_s + W_q = 3+214 \text{ days} = 3.5 \text{ years}$ . Thus, our waiting costs are fixed  $= \lambda W C_w = (24)(3.5)(500) = 42000\$/\text{day}$ .

The only changing parameter is: $s$ (number of beds)									
Scenario: $\lambda = 2 \text{ seniors/month}, \mu = 1 \text{ senior/3 years (0.33 senior/year)}$									
Condition: $s\mu > \lambda = 0.33s > 24 \Rightarrow s = 73 \text{ beds minimum}$									
Case	$s$	$C_s/\text{Day}$	$\lambda$	$\mu = 1/W_s$	$W = W_s + W_q$	$L = \lambda W$	$C_w/\text{Day}$	Utilization $= \lambda/s\mu$	Total Cost/Day
9	74	300\$	24/year	0.33/year	3.5 years	84	500\$	98.28%	64200\$/day
10	75	300\$	24/year	0.33/year	3.5 years	84	500\$	96.87%	64500\$/day
11	78	300\$	24/year	0.33/year	3.5 years	84	500\$	93.24%	65400\$/day
12	80	300\$	24/year	0.33/year	3.5 years	84	500\$	90.91%	66000\$/day
13	85	300\$	24/year	0.33/year	3.5 years	84	500\$	85.56%	67500\$/day
14	90	300\$	24/year	0.33/year	3.5 years	84	500\$	80.81%	69000\$/day
15	95	300\$	24/year	0.33/year	3.5 years	84	500\$	76.56%	70500\$/day
16	100	300\$	24/year	0.33/year	3.5 years	84	500\$	72.73%	72000\$/day

**Table 5.4:** M/D/s cost model results 1

The results are represented in the figure above:

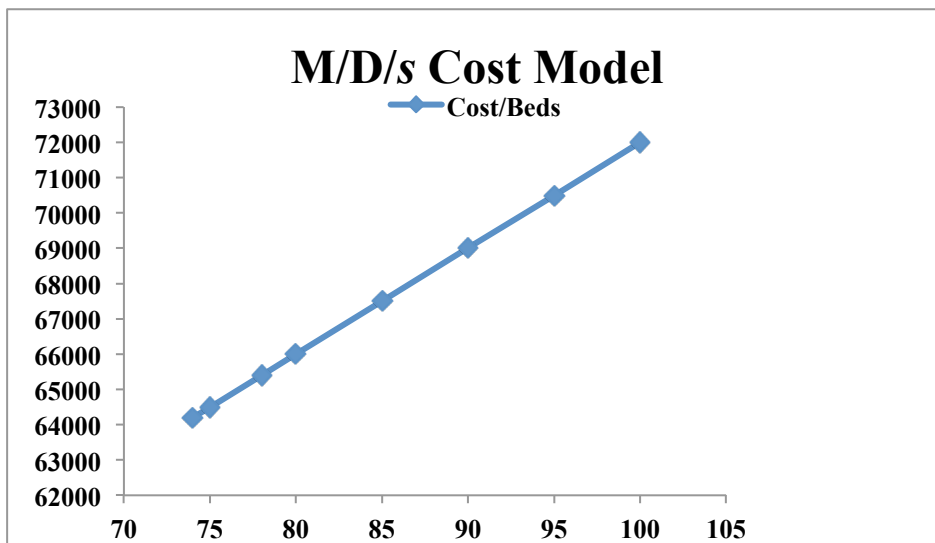

**Figure 5.17:** M/D/s cost model results

From the results, we conclude that when the arrival rate and service time are fixed (fixed waiting costs); the more staffing (bedding) is provided, the more expensive is the daily cost. Sticking to the lowest number of beds possible for the system to run smoothly is best. Looking for other solution, like homecare to decrease the waiting list is recommended.

We keep the same parameters as the previous test, the only changing parameter is: the arrival rate. The results are shown below:

<b>The only changing parameter is: <math>\lambda</math> (number of beds)</b>									
<b><math>\mu = 1</math> senior/3 years (0.33 senior/year) Condition for basic scenario: <math>s\mu &gt; \lambda = 0.33s &gt; 24 \Rightarrow s = 73</math> beds minimum</b>									
<b>Case</b>	$s$	$C_s/\text{Day}$	$\lambda$	$\mu = 1/W_s$	$W = W_s + W_q$	$L = \lambda W$	$C_w/\text{Day}$	Utilization = $\lambda/s\mu$	Total Cost/Day
<b>9</b>	74	300\$	24/year	0.33/year	3.5 years	84	500\$	98.28%	64200\$/day
<b>15</b>	74	300\$	36/year	0.33/year	3.5 years	126	500\$	147.42%	85200\$/day
<b>16</b>	<b>74</b>	<b>300\$</b>	<b>12/year</b>	<b>0.33/year</b>	<b>3.5 years</b>	<b>42</b>	<b>500\$</b>	<b>49.14%</b>	<b>43200\$/day</b>
<b>Keep the same changing arrival rates. Let's Increase the beds' number and see the effects on the daily cost?</b>									
<b>17</b>	80	300\$	24/year	0.33/year	3.5 years	84	500\$	90.91%	66000\$/day
<b>18</b>	80	300\$	36/year	0.33/year	3.5 years	126	500\$	136.36%	87000\$/day
<b>19</b>	<b>80</b>	<b>300\$</b>	<b>12/year</b>	<b>0.33/year</b>	<b>3.5 years</b>	<b>42</b>	<b>500\$</b>	<b>45.45%</b>	<b>45000\$/day</b>

**Table 5.5:** M/D/s cost model results 2

The results show that when the arrival rate increases, it results in an overcrowded system. Thus, waiting costs will skyrocket and automatically the total daily costs increases. If the arrival rate decreases, the waiting costs will automatically decrease and results in a total costs decrease as well. We conclude that finding a solution on how to decrease the arrival rate (home and ALC waiting list and the risks associated with them both) will result in a huge decrease on the daily costs of a nursing home. The recommended solution is: Home care programs.

Case	$s$	$C_s/\text{Day}$	$\lambda$	$\mu = 1/W_s$	$W = W_s + W_q$	$L = \lambda W$	$C_w/\text{Day}$	Utilization: $\lambda/s\mu$	Total Cost/Day
4	80	300\$	24/year	0.33/year	3.16 years	75.77	500\$	90.91%	61885\$/day
9	74	300\$	24/year	0.33/year	3.5 years	84	500\$	98.28%	64200\$/day
16	74	300\$	12/year	0.33/year	3.5 years	42	500\$	49.14%	43200\$/day

**Table 5.6:** Comparison between M/M/s and M/D/s cost models results

As we can see, case 4 is the best because it gives the best results (lowest total cost, best total service and waiting time, fair system utilization).

Case 9 is not recommended, as it is more costly than the other two cases.

Case 16, would be beneficial if the cost of lowering the arrival rate is low and won't cause the total cost to increase over the total cost of case 4. Also, the utilization is really low (half of the system bedding only), using the vacant beds for ALC patients is recommended.

# Chapter 6

## Conclusion

---

Aging population in Nova Scotia is putting a strain on the Continuing care system. Researchers and policymakers are faced with the burden of finding a solution before the baby boom generation hits their 60s. This thesis is a partial contribution to the solution.

### 6.1. Contributions & Results

In this thesis, a data analysis and queuing models are developed to study the problem of congested alternative level of care and long term care in Nova Scotia. First, in our data analysis, the problem is addressed by studying the real data (number of beds, placements, people in pending state in 9 DHAs), we find that the turnover rates of beds in 7 DHAs are very close, and DHA 4 and DHA 8 have relative lower turnover rates. To reduce the number of people at ALC/LTC, if no new resources can be added, the possible way is moving a senior in as soon as a bed is available. This can be done by information sharing between the hospital, the patient, and the placement office and care providers. Also, improving the discharge quality instead of shortening the time of discharge process is another key. Second, a discrete period Markov chain model is used to measure the average waiting time of seniors in nursing homes. In this model, two approaches were compared: The expanding and shunting approach. The two approaches tend to be sensitive to the model parameters values, where they switch positions in reducing the nursing home waiting to a minimum possible. However, the expanding approach tends to have best results mostly. Thus, the expanding approach is recommended. Third, a M/M/s queuing model is applied to nursing homes. A scenario analysis was used to see how the changing system parameters affect each other.

Optimum system parameters for best resource allocation and best waiting time were defined. Lastly, a cost model balancing waiting and service costs for optimum total costs was provided.

## 6.2. Government Actions and Options on Continuing Care

### 6.2.1. The Build More Option

#### **Funding ALC**

Expanding acute care capacity will improve emergency admission rates, shorten elective surgeries wait times, and lessen the pressure on ALC and LTC. This solution is a costly temporary fix. It should be implemented with the respect of timely and safe post acute care discharges, or it will lead to more acute beds being occupied by ALC patients. Thus, worsening the current problem [35].

In British Columbia, initiatives to reduce demand for hospital-based care include rapid access clinics, outreach teams and active care management. Health Authorities are also providing transitional care beds. These beds are a lower cost alternative to acute care, but still provide the proximity of hospital-based support [36]. In Ontario, transitional care beds are being added to acute care hospitals, temporary long-term care beds are being created and specialized continuing care programs for hospitalized dementia patients are being implemented [36]. In Nova Scotia, the government is planning on opening new acute care facilities [37].

#### **Funding LTC and Home Care Programs**

Increasing capacity in post acute care is probably a mutual solution to both ALC and LTC waiting list and capacity shortage problems. The benefit of this option is that ALC patients will be discharged, vacate acute beds and facilitate more hospital admissions. In the

other hand, this option is costly: Provincial governments will have to increase healthcare spending and policy makers will have to identify the post acute care that ALC patients are in the most need for. The reality is that healthcare budgets are in a real strain, and expanding capacity is costly with no guarantee of success [35].

In Canada, reducing the demand for hospital and long-term care beds is based on several province-wide initiatives. In British Columbia, constraints in the capacity of long-term care are addressed by supplementing home care support until a long-term care bed opens. Specific programs designed to substitute for long-term care include respite care, palliative care, adult day services and home care services (including training for home care staff) [36]. In Ontario, The Aging at Home Strategy of the Ministry of Health and Long-Term Care (MoHLTC) is being used to reduce inefficient insufficient ALC and LTC. Few initiatives are: (1) improving patient flow between care providers by integrating hospital care, home care and community care access centers, (2) increasing capacity for some types of continuing care (home care services, supportive services). Specifically, increase the amount of personal support, homemaking and nursing services at home. The initiative is targeting high-risk, frail and cognitively impaired seniors [36].

The Figure below shows Nova Scotia's government and DHW actions to solve ALC/LTC problem:



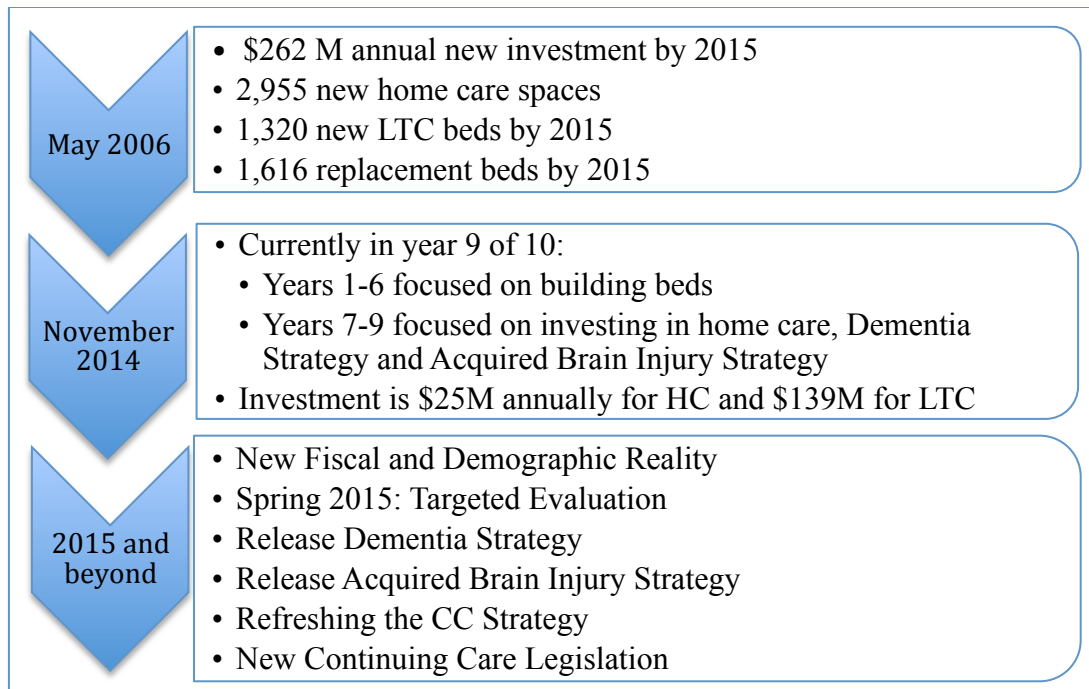

**Figure 6.1:** Nova Scotia’s ALC/LTC actions (Continuing Care Strategy) [33].

### 6.2.2. The Integrated Care Option

Close relationships between acute and post-acute care providers have been proposed as a way to improve the efficiency and effectiveness of healthcare resource use and reduce failures of transitional care between settings [103, 104]. Integrated healthcare delivery may minimize the number of ALC patients, because integrated models have the administrative authority and the financial incentives to ensure that patients are treated at the lowest-cost provider appropriate for their condition [105].

Effective integrated care models are largely based in the United States. They are privately operated, often with salaried physicians, and have tightly networked their funding and delivery methods. These systems are not generalizable to the Canadian setting, where physicians are remunerated by the province, rewarded for how “much” they do, and whose costs are externalized from the effects of inefficient hospital care. Also, many post-acute care providers are privately owned and do not share hospitals’ community mission [106].

One integrated care model from the United States is the Program Care for the Elderly (PACE). Designed for those 55 and older having complex needs and to whom care is provided in the community rather than in a nursing home. PACE providers receive a monthly payment for each patient they care for; thus, they have a financial incentive to keep patients out of hospital. PACE evaluations have reported significant reductions in hospital utilization and improved quality of care [107, 108].

A project similar to PACE was piloted in Quebec, raising the prospect of integrated models of care in Canada. Services Intégrés pour les Personnes Agées en Perte d'Autonomie (SIPA) project aims to evaluate the performance of integrated community health and social services compared to usual care. Costs of community-based services were higher for the integrated care group compared to the usual care group, but facility-based costs were lower. The integrated care group experienced a 50% reduction in ALC occupancy [86].

Following the U.S. program PACE, Alberta introduced a Comprehensive Home Option of Integrated Care for the Elderly (CHOICE) program to provide intensive services to frail seniors or those with chronic mental issues. The Capital Health CHOICE program is in operation for 10 years and currently serving close to 400 seniors, has demonstrated success through improved health outcomes, client and family satisfaction and a significant reduction in use of acute and emergency care [35].

### **6.2.3. The Financial Incentives Option**

Creating financial incentives to improve the quantity, quality or effectiveness of healthcare is not the norm in Canadian provinces, as it is frequently associated with private, for-profit care. However, there is evidence from other countries with strong, publicly funded

healthcare systems, such as Australia, the United Kingdom, and many European countries that healthcare institutions respond to financial incentives [87].

Hospitals and acute care across Canada have been funded by global budget. A global budget is a single payment aiming to fund all care over a given period, no matter the volume or type of care provided (Alberta and Ontario’s LTC sector are the exception). Global budgets create incentives for cost controls, and leave the hospital or post-acute care providers at risk for changes in volume or complexity of patients [109].

Recently introduced activity-based funding initiatives for hospitals in British Columbia and Ontario are motivating hospitals to “push” patients from acute care (because new admissions generate additional revenue). British Columbia is also providing financial incentives for community-based programs [36].

Similar financial incentives could be developed for post-acute care providers to admit acute care patients and create capacity for ALC patients. These policies necessitate surveillance on quality, payments based on the complexity of care needs, and linking practice guidelines to pattern of care. Thus, ensure that patients are not discharged too early or being cared for inappropriately. Also, assure that care providers were not admitting only patients who are less costly (than the payment amount) to care for, or refusing admission to complex and costly patients [36, 110].

## 6.3. Recommendations and Solutions

### 6.3.1. Adopt a Province Wide “Home First” Plans

The home can be an appropriate and cost-effective place to provide care for chronic conditions and it is typically where people want to be. When appropriate resources are in place, home care can result in better health outcomes, slowed deterioration, and may even

slow or stop long-term need [111].

Cape Breton DHA8 implemented a program that was already adopted in Ontario. The program provides home care services to would-be ALC patients. Medically stable inpatients in the hospital transition unit are provided with enhanced home care hours and supports, in order to wait in their own residence for long-term care placement. Additional and targeted staffing, particularly in the physiotherapy and occupational therapy sectors, would be necessary [112]. The program has proven valuable in Ontario, and planned to be expanded not only within Cape Breton, but also throughout Nova Scotia [113].

The “Home First” program principal is that people should be in their own homes whenever it is safely possible. It is known that frail seniors are most appropriately cared for in the long-term care environment. Decision-makers favor least-risk care decisions, thus, frail seniors can be put on the long-term care list without consideration of home care [111].

In the United Kingdom, a “balance of care” program that aims to allow a person to be functional in the home environment was used [114]. Denmark, has intentionally not built a new nursing home since 1987, preferring to invest in formal home care delivery [115].

### **6.3.2. Adjust the Discharge Planning Process**

Discharge planning should begin at the time of admission. This principle is used elsewhere with great success [112, 116]. Generally, data can indicate how many days a patient with a particular profile will require in hospital. For example, the average length of ALC bed stay in Nova Scotia is 110 days [37]. Under “home first program”, discharge dates may become more predictable and shorter, given anticipated expansions in home and community supports. Regardless of the end destination, defining the discharge date in advance allows all stakeholders (the individual, family, and service providers) to understand

their accountabilities and have appropriate measures (e.g., supports, paperwork, etc.) completed in advance for a smooth transition.

Discharges decision should also be by a multidisciplinary team, including the patient, family/caregivers, social worker, physiotherapist, occupational therapist, and a physician. It should also involve primary care providers in the community [111].

Discharge could be occurring seven days a week [111]. The current practice in hospitals leads one to believe that the task of discharge coordination is undefined. Staff should be aware of their responsibilities in the discharge process and should work to fulfill this role. Of course, for discharge to occur all days, home care agencies would have to be supported and prepared to accept clients, and the necessary arrangements should be made.

### **6.3.3. Improve Gaps in Provider-to-Provider Communication**

Smooth transition and integration are key elements of a successful discharge process [117]. If a decision is made for a person to receive supports outside the hospital, communication between acute, long term, home and community care systems is pivotal.

Systemic communication mechanisms between DHAs and continuing care organizations remain lacking, particularly as they relate to discharge, and thus the transition process is slowed. New protocol for advanced planning discharge, with tools such as the newly developed provincial discharge/transfer tool, may start to improve communication; however, neither is sufficiently comprehensive to facilitate best possible communication between health care providers. The DHAs, in partnership with home care agencies, should develop a set of guidelines that would include all of the patient's information, care providers responsibilities are ready and communicated in advance of a projected discharge date [111].

### 6.3.4. Recommendations List

A list of recommendations is as follows:

1. Implement a sophisticated province wide Home care plan to reduce ALC waiting list. Allowing patients who qualify for home care (acute, chronic, palliative) programs leave the hospital for a more convenient care environment (home). Thus, other ALC patients will have a better chance to benefit from other continuing care programs and institutions. Also, the pressure put on long term care will be reduced.
2. Launch programs to educate patients' family members about the negative outcomes and risks of ALC and nursing home care and the positive role they play themselves, and encourage them to find a better way to take care of their loved ones at home with home care help and support. According to [33], family and friend caregivers provide 70-80% of care needed and the formal system provides 20-30%. Therefore, supporting caregivers is critically important.
3. Review Admission-Discharge-Transfer policies. More specifically: Reduce the number of LTC facilities a patient is illegible to simultaneously apply for from (Unlimited in Nova Scotia/5 in Ontario) to 2 facilities maximum. Why? It may seem that the name of the same patient appearing on multiple nursing homes waiting list doesn't affect the main waiting list in the DHW because he appears only once at the main list. However, it does affect it in a way that a patient refusal to a bed offer in a specific nursing home and wait for the next nursing home offer may effect the waiting time of another waiting patient. Limiting a patient to choose only 2 of the best nursing homes he wants to be in, will decrease wasted (admission, re-assessment) time. Also, limiting patients' transfers would be beneficial (unless a

transfer is a must: like home distance convenience for family members to visit, offered activities and care match the patient's needs...). This issue wasn't addressed in the 2015 government policy. Nova Scotia's patients are still illegible to apply for unlimited nursing home at once if qualified and may transfer easily if they prefer to do so.

4. Reduce the period a patient can postpone a nursing home bed offer from 3 months to 1 week maximum (According to Nova Scotia Government, this issue had been taken in action. "As of March 2, 2015, clients waiting in the community for placement in a long term care facility will no longer have the option to defer placement until a later date. When the client receives a bed offer, they must either accept or refuse the bed") [80]. This action may help in future waiting list decrease.
5. Review all the Nursing homes staffs level and adjust the fund for the short-staffed and under-funded nursing homes. Why and How? For example, a nursing home has some vacant beds while ALC senior patients' are waiting for a bed in that specific nursing home. However, that nursing home isn't able of accepting a new patient because of a lucking staffs (nurses). A solution would be to provide that nursing home with the needed nurses instead of paying costly ALC, putting hospital staffs under pressure and risking the patient to have health deterioration. Also, allow nursing/staffs transfer in crisis situations: For example, if a nursing home lacks nurses, while another has idle staffs. Transfers-in between-institutions might be a good temporary solution. Especially if work-home distance is convenient, if not the case, bonus payment for nurses is advisable (it would be less costly than leaving a patient in ALC).

6. Implement a quality-monitoring program to make sure that a smooth discharge process and good quality care is considered in LTC/HC institutions: Like viewing patients' conditions and matching them with their placement dates, doing surveys with patients and care givers, and visits to care place (Institutions) for quality monitoring.
7. Labeling and clustering nursing homes by the type of care offered would be beneficial for assessment conductors, care providers and patients and their families. It is known that nursing homes are for the most frail patients, and residential care facilities and home care offer less extensive care, however it would be a good idea to separate nursing homes according to frail patients groups: Dementia patients, physically disable patients...etc. This will make management and care easier and of better quality.
8. Consider a parallel public/private sector LTC system, because trying to only increase the public sector budget might not be the ultimate solution. Why? Some patients in the waiting list are able to pay for private care while they are either in ALC or waiting at home for a spot in LTC. In the other hand, some patients who are able to pay for private care are benefiting from public care, while poor patients are waiting for a bed offer. Thus, private care will elevate the pressure on the waiting list and offer more flexible options for patients. Some researchers argue that private care may push public health providers to decrease the quality of care offered. We think that this can be avoided if the government puts conditions on the quality of public care if private care is implemented.
9. DHW should re-consider the old policy of Funding LTC facilities upon occupancy



rate, instead of the actual budget funding policy: Why? Funding LTC facilities according to their occupied beds may push their managers to work in a more efficient way to fill those idle vacant beds.

10. Care providers and placement coordinators should be given pre-training/education in new continuing care acts and policies before it is implemented/in action. This will avoid confusion and delays in transfers and placement because of new policy misunderstanding.
11. Design the same standard set of words for Nursing personnel skills and post-discharge care. Use the standard on both the provider and patient side to describe the patient's demands. Then, it will be easy to match the supply with the demand when hospitals assign patients or patient family consider where to apply for the long-term care.
12. Forecast the post-discharged care for patients. According to The Ministry of Health and LTC, recovery times from planned surgeries are often fairly predictable. This will allow the care and discharge processes go smoothly, because care providers and placement advisors will have enough time to organize discharge steps ahead of discharge date. Thus, no delays because of paper and process arrangements.
13. Provide a standard post-discharged care for each type of patients. Let the long-term care homes charge certain fee if a patient asks for higher requirements: This is what is actually happening in nursing homes. A patient is offered a standard list of insured services (included in the accommodation fees paid by the patient), and another list of optional services (the patient has to pay for these extra services if chosen). Note: Care fees are paid by the DHW.

14. Strictly perform the management policy. When the system is ready for a patient to leave, and the patient does not follow the guidelines, he should get penalized. In practice, the penalty policies were not performed. Thus, patients will not worry about the management policies in future. If patient is discharged, care providers have to make sure that the discharged patient is affiliated to the right type of care/institution needed, because if not the case his health may deteriorate from the inadequate care provided.
15. Preparing the patients emotionally for discharge to avoid any discharge refusal: For example making the patient aware of his discharge date at least a week before, thus, he has enough time to prepare (him/herself) emotionally to leave the (hospital/home) for an (home/institution). Also, care givers and family members will have enough time to prepare a care environment that fits the patient needs.

## 6.4. Suggestions for Future Work

In this thesis we modeled the case of one nursing home & the case of the LTC system using Markov chains and queuing theory, no patients' behaviors had been taken in consideration. A case of many (Hospitals (ALC), HC services, and the whole continuing care system) can be investigated as well using the same Markov chain model we used or it can be addressed by using a Jackson network. Also, the congestion appearing in the different nodes (ALC, LTC, HC) of the network can be addressed by using a network with blocking, where the blocking time can be added to the waiting time. Moreover, a priority model where ALC and LTC patients can be classified by priority, and only very needy seniors can access LTC and the rest can be offered HC services. In addition, patients who are in a very need of LTC, however, they don't join the queue because of the long waiting

time; can be addressed using a model with balking. Furthermore, patients who get tired from waiting so long and leave the queue looking for a substitute service somewhere else can be addressed using a model with reneging. Lastly, considering the patients who have been offered a LTC service, leave and return to the waiting queue again can be addressed using a model with recycling. Below, is a Jackson network proposed solution for Nova Scotia's continuing care system:

#### **6.4.1. An Open Jackson Queuing Network**

In this network, we assume that every long-term care institution is a station in the network. The considered LTC institutions are: (a) Nursing homes, (b) residential care facilities and community based options. The offered types of care for seniors outside the LTC system are considered in two groups: (c) homecare (d) alternative level of care (ALC). Thus, we will end up having 4 stations in the network: (a), (b), (c), and (d). These stations are modeled using M/M/s model for each station, where we don't take the number of beds as the number of servers, but the number of the facilities as the servers. For example if we have 10 nursing homes in Nova Scotia, then we will have 10 servers (M/M/10 model) to model the stations (a): NHs. We do the same for the other 3 stations. The availability of a bed in any facility in a station would be taken as a server availability, no matter which facility the patient is referred to. For example, in Nova Scotia if a bed is available in any nursing home, a patient in the waiting list is in need of that particular service, the bed will be assigned to that patient without regard of the location (means if the type of care is what is needed, we don't consider the patient's location as a challenge), or any other factors.

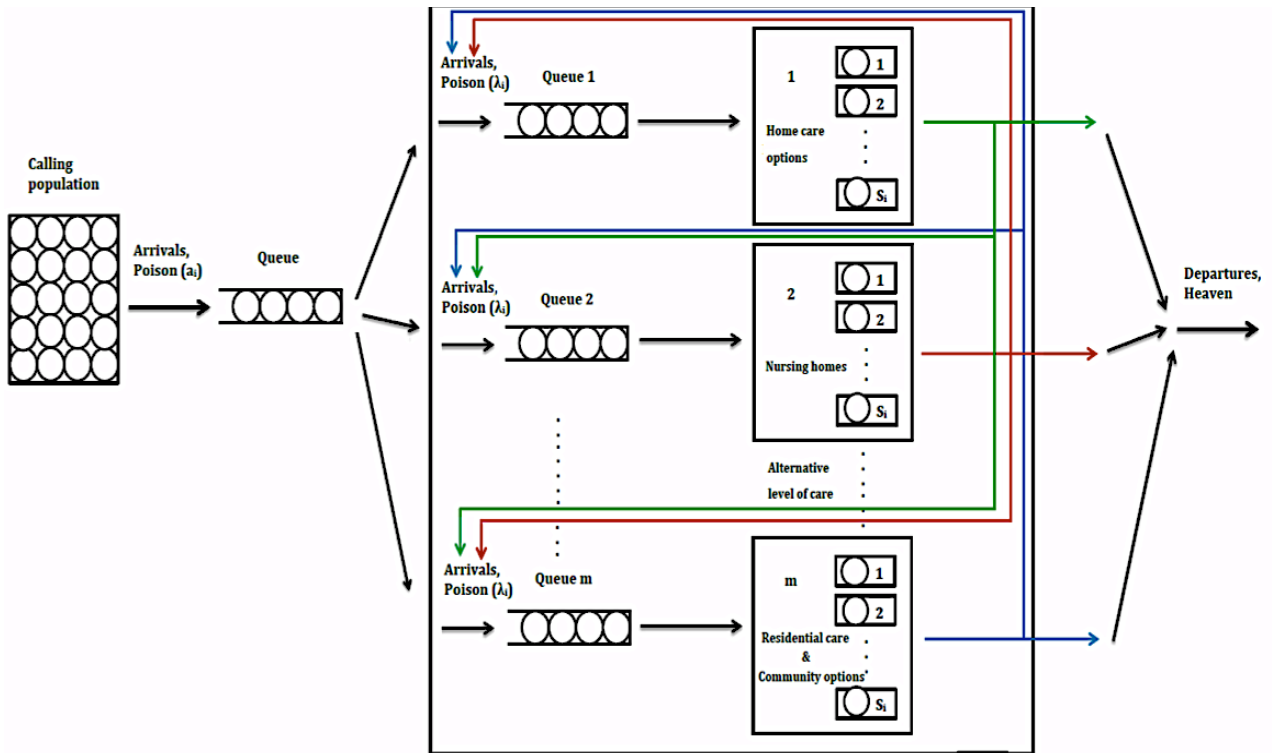

Figure 6.2: An open Jackson network for LTC in NS

#### 6.4.2. Jackson Network Assumptions

1. An infinite queue, with FCFS discipline, no priority.
2. Seniors arrive from outside the system according to a Poisson process, parameter  $a_i$
3.  $s_i$  Facilities (a, b, c, d) with an exponential service time distribution, parameter  $\mu_i$

A senior leaving facility  $i$  is routed next to facility  $j$  ( $j = 1, 2, \dots, m$ ) with probability:  $p_{ij}$

or departs the system with probability:  $q_i = 1 - \sum p_{ij}, (j = 1, 2, \dots, m), i \neq j$

Under steady-state conditions, each facility  $j$  ( $j = 1, 2, \dots, m$ ) in the network behaves as if it

were an independent M/M/s queuing system with arrival rate:  $\lambda_j = a_j + \sum \lambda_i p_{ij}$ ,

where: ( $i = 1, 2, \dots, m$ ) and  $s_j \mu_j > \lambda_j$

4. The network facilities (a, b, c, d) are working at their full capacity.
5. Facilities here represents NHs, HC services, RCFs and ALC
6. Service rate is independent of line length; services don't fasten up if the line is long.

# References

- [1] C. Eliopoulos, *Gerontological Nursing*, 7th ed. Philadelphia, PA: Wolters Kluwer Health/Lippincott Williams & Wilkins, 2010.
- [2] World Health Organization, *Active Aging: A Policy Framework*. Geneva, World Health Organization, 2002
- [3] B. Postl et al, "Health Care in Canada: A Focus on Seniors and Aging", Canadian Institute of Health Information, 2011.
- [4] Statistics Canada, *Population Projections for Canada, Provinces and Territories: 2009 to 2036*, Ottawa: Ont. Catalogue no. 91-520-X, 2010.
- [5] Statistics Canada, *Census Profile, 2012*. Retrieved from: <http://www.statcan.gc.ca/start-debut-eng.html>
- [6] CBC News Report, *Wait lists for long-term care growing: report*, 2011. Retrieved from: <http://www.cbc.ca/news/canada/nova-scotia/wait-lists-for-long-term-care-growing-report-1.981595>.
- [7] *Continuing Care Strategy, 2012*. Retrieved from [http://www.nshrf.ca/sites/default/files/continuing\\_care\\_strategy\\_attachment.pdf](http://www.nshrf.ca/sites/default/files/continuing_care_strategy_attachment.pdf)
- [8] C. Mellor, "More than 2,400 Nova Scotia seniors await home spots", *Herald News*, 2013, Retrieved from: <http://thechronicleherald.ca/novascotia/1136971-more-than-2400-nova-scotia-seniors-await-home-spots>
- [9] D. Jackson, "New nursing home beds put on hold", *Herald News*, 2013. Retrieved from: <http://thechronicleherald.ca/novascotia/403918-new-nursing-home-beds-put-on-hold>
- [10] M. Gorman, "Care in Crisis", *The Chronicle Herald and Nova Scotia Department of Health and Wellness*, 2013. Retrieved from: <http://thechronicleherald.ca/careincrisis/1167301-wait-times-around-nova-scotia#.VTFgmkud4ds>
- [11] L. Glavine, "A Place to Call Home", Minister of Health and Wellness, *Long-Term Care, A Safe and Secure Environment Conference*.
- [12] Department of Health and Wellness, *Continuing Care Dashboard, DHW*, 2014.
- [13] Province of Nova Scotia, *Budget 2014/2015: Assumptions and Schedules*, 2014.
- [14] Province of Nova Scotia, *Budget 2014/2015: Address*, 2014.

- [15] Canadian Institute of Health Information, *Seniors and Alternate Level of Care: Building on Our Knowledge*, 2012.
- [16] Ontario Association of Community Care Access Centers, Ontario Association of Non-Profit Homes and Services for Seniors, Ontario Hospital Association, and Ontario Long-Term Care Association, *Alternate Level of Care-Challenges and Opportunities: A Collaborative Position Paper*, Toronto: Ontario Hospital Association, May 2006.
- [17] Canadian Institute of Health Information, *Alternative Level of Care in Canada*, 2009.
- [18] J. Restakis, "Co-op Elder Care in Canada", British Columbia Co-Operative Association, British Columbia, 2008.
- [19] A. Banerjee, "An Overview of Long-Term Care in Canada and Selected Provinces and Territories", *York University, Institute of Health Research*, 2007.
- [20] B. C. Vladeck, "Unloving Care Revisited: The Persistence of Culture". In A. S. Weiner and J. L. Ronch (eds.), *Culture Change in Long Term Care*, Haworth Social Work Practice Press, Binghamton: NY, pp. 1–9, 2003
- [21] B. Havens, "Users of Long-Term Care". In M. Stephenson and E. Sawyer (eds.), *Continuing the Care: The Issues and Challenges for Long-Term Care*, Ottawa, ON, CHA Press, pp. 87–107, 2002.
- [22] Health Association Nova Scotia, *Continuing Care Programs*, 2013. Retrieved from: <http://www.healthassociation.ns.ca>
- [23] Nova Scotia Department of Health and Wellness, *Continuing Care, Introduction to Continuing Care*, 2013. Retrieved from: <http://novascotia.ca/dhw/ccs/>
- [24] Nova Scotia Department of Health and Wellness, *Continuing Care, Home Care*, 2013. Retrieved from: <http://novascotia.ca/dhw/ccs/home-care.asp>
- [25] Nova Scotia Department of Health and Wellness, *Continuing Care, Long Term Care facilities*, 2013. Retrieved from: <http://novascotia.ca/dhw/ccs/>
- [26] Sun Life Assurance Company of Canada, *Long Term Care in Nova Scotia 2013*, 2013. Retrieved from: <https://www.sunnet.sunlife.com/files/advisor/english/PDF/Completereport-LTC-Costs-NS.pdf>
- [27] Nursing Homes Ratings, *Understanding The Nursing Home System*, 2013. Retrieved from: <http://www.nursinghomeratings.ca/understand-the-nursing-home-system>
- [28] Statistics Canada, Health Statistics Division, *Residential Care Facilities*, no. 83–237-X, 2011. Retrieved from: [www.statcan.gc.ca](http://www.statcan.gc.ca)

- [29] CBC News, Canada's nursing homes, 2014. Retrieved from: <http://www.cbc.ca/news2/interactives/map-nursing-homes/>
- [30] Department of Health and Wellness, Removing Barriers in Accessing Long Term Care, 2011.
- [31] Nova Scotia Department of Health and Wellness, Continuing Care, What is Home Care?, 2013. Retrieved from: <http://novascotia.ca/dhw/ccs/>
- [32] Nova Scotia Department of Health and Wellness, Home Care Policy Manual, June 2011.
- [33] S. Stevens, "Continuing Care Updates and Trends", Continuing care, Department of Health and Wellness, 2014.
- [34] Cancer Care Ontario, Provincial Alternate Level of Care (ALC) Definition: Practical Guide for Clinicians, July 2009.
- [35] J. M. Sutherland & R.T. Crump, "Alternative Level of Care: Canada's Hospital Beds, the evidence and Options", *Healthcare Policy*, vol. 9, no. 1, pp. 26–34, 2013.
- [36] J. M. Sutherland & R.T. Crump, Canadian Health Services Research Foundation, "Exploring alternative level of care (ALC) and the role of funding policies: An evolving evidence base for Canada", 2011.
- [37] Data on Alternative Level of Care, Appendix A, 2013. Retrieved from: <https://www.cma.ca/Assets/assets-library/document/en/advocacy/appendices-to-cma-infrastructure-submission-en.pdf>
- [38] A. P. Sankarsingh, Department of Health and Wellness, 2015.
- [39] A. S. Ostry, M. Katrina, M. Tomlin, Y. Cvitkovich, A. P. Ratner, Il H. Park, R. B. Tate, A. Yassi, "Choosing a model of care for alternate level care patients: Caregivers' perspectives with respect to staff injury", *Canadian Journal of Nursing Research*, vol. 36, no. 1. pp. 142–157, 2004.
- [40] Canadian Institute for Health Information, Alternate level of care in Canada, Tech. rep, 2009.
- [41] S. Stidham, "Analysis, design and control of queuing systems", *Operations Research*, vol. 50, no. 1. pp. 197–216, 2002.
- [42] F. S. Hillier and G. J. Lieberman, "Queuing Theory", in *Introduction to Operations Research*, 5<sup>th</sup> ed, McGraw-Hill, Inc, US, 1990.
- [43] Y. A. Ozcan, "Queuing models and capacity planning", In Chapter fourteen (2<sup>nd</sup> Ed), *Quantitative Methods in Health Care Management: Techniques and Applications*, Jossey-Bass, pp. 345–372, 2009

- [44] S. Vikas, "Use of Queuing Models in Health Care", University of Arkansas for Medical Sciences, *Department of Health Policy and Management*, 2006. Retrieved from [http://works.bepress.com/vikas\\_singh/4](http://works.bepress.com/vikas_singh/4)
- [45] N. Ameh, B. Sabo & M. O. Oyefabi, "Application of queuing theory to patient satisfaction at a tertiary hospital in Nigeria", *Nigerian Medical Journal*, vol. 54, no. 1, pp. 64–7, 2013.
- [46] D. Gupta, "Queuing Models for Healthcare Operations", In B.T. Denton (ed.), *Handbook of Healthcare Operations Management: Methods and Applications, International Series in Operations Research & Management Science*, New York: Springer Science, Business Media, pp. 19–44, 2013.
- [47] G. Bolch, S. Greiner, H. de Meer, and K.S. Trivedi, "Queuing Networks and Markov Chains: Modeling and Performance Evaluation with Computer Science Applications", John Wiley & Sons, Inc., London, 1998.
- [48] B. Filipowicz, "Modeling and analysis of queuing networks", *Wydawnictwa AGH, Kraków*, 1997.
- [49] S. Creemers. and R. Lambrecht, "Modeling a Healthcare System as a Queuing Network: The case of a Belgian Hospital". *Department of Decision Sciences & Information Management, Katholieke Universiteit, Leuven: Belgium*, 2007.
- [50] R. Mehendiratta, "Applications of queuing theory in health care", *International Journal of Computing and Business Research*, vol. 2, no. 2, pp. 2229–6166, 2011.
- [51] R. A. Nosek and J. P. Wilson, "Queuing Theory and Customer Satisfaction: A Review of Terminology, Trends and Applications to Pharmacy Practice", *Hospital Pharmacy*, vol. 36, pp. 275–276, 2001.
- [52] J. Preater, "Queues in health", *Health Care Management Science*, vol. 5, no. 283, 2002.
- [53] L. Green, "Queuing analysis in healthcare", in R. W. Hall, *Patient Flow: Reducing Delay in Healthcare Delivery*, ed., New York, Springer, pp. 281–308, 2006.
- [54] J. R. Broyles and J. K. Cochran, "Estimating business loss to a hospital emergency department from patient renegeing by queuing-based regression", *Industrial Engineering Research Conference*, pp. 613–618, 2007.
- [55] K. T. Roche, K. J. Cochran, and I. A. Fulton, "Improving patient safety by maximizing fast-track benefits in the emergency department: a queuing network approach", *Industrial Engineering Research Conference*, pp. 619–624, 2007.
- [56] D. J. Worthington, "Hospital waiting list management models", *The Journal of the Operational Research Society*, vol. 42, pp. 833–843, 1991.



- [57] D. J. Worthington, "Queuing Models for Hospital Waiting Lists", *The Journal of the Operation Research Society*, vol.38, pp. 413–422, 1987.
- [58] C. J. Rosenquist, "Queuing analysis: a useful planning and management technique for radiology", *Journal of Medical Systems*, vol. 11, pp. 413–419, 1987.
- [59] D. G. McQuarrie, "Hospital utilization levels: The application of queuing theory to a controversial medical economic problem", *Minnesota Medicine*, vol. 66, pp. 679–86, 1983.
- [60] K. Siddhartan, W. J. Jones, and J. A. Johnson, "A priority queuing model to reduce waiting times in emergency care", *International Journal of Health Care Quality Assurance*, vol. 9, pp. 10–16, 1996.
- [61] D. Fiems, G. Koole, and P. Nain, "Waiting times of scheduled patients in the presence of emergency requests", 2007. Retrieved from: <http://www.gerkoole.com>
- [62] S. R. Agnihotri and P. F. Taylor, "Staffing a centralized appointment scheduling department in Lourdes Hospital", *Interfaces*, vol. 21, pp. 1–11, 1991.
- [63] A.M. Bruin, A.C. Rossum, M. C. Visser, and G. M. Koole, "Modeling the emergency cardiac in-patient flow: an application of queuing theory", *Health Care Management Science*, vol. 10, pp. 125–137, 2007.
- [64] J. B. Tucker, J. E. Barone, J. Cecere, R.G. Blabey, and C. Rha, "Using queuing theory to determine operating room staffing needs", *Journal of Trauma*, vol. 46, pp. 71–79, 1999.
- [65] F. Gorunescu, S. I. McClean, and P. H. Millard, "A queuing model for bed-occupancy management and planning hospitals", *Journal of the Operational Research Society*, vol. 53, pp. 19–24, 2002.
- [66] C. J. Rosenquist, "Queuing analysis: a useful planning and management technique for radiology" *Journal of Medical Systems*, vol. 11, pp. 413–419, 1987.
- [67] M. Brahim, and D.J. Worthington, "Queuing models for out-patient appointment systems – a case study", *The Journal of the Operational Research Society*, vol. 42, pp. 733–746, 1991.
- [68] P. DeLaurentis, R. Kopach, R. Rardin, M. Lawley, K. Muthuraman, H. Wan, L. Ozsen, and P. Intrevado, "Open access appointment scheduling – an experience at a community clinic", *IIE Annual Conference and Exposition*, 2006.
- [69] S.L. Albin, J. Barrett, and J.E. Mueller, "A queuing network analysis of a health center", *Queuing Systems*, vol. 7, pp. 51–61, 1990.
- [70] E. P .C. Kao and G.G. Tung, "Bed allocation in a public health care delivery system", *Management Science*, vol. 27, pp. 507–520, 1981.

- [71] E. L. Blair and C. E. Lawrence, "A queuing network approach to health care planning with an application to burn care in New York state", *Socio-economic Planning Sciences*, vol. 15, pp. 207–216, 1981.
- [72] C.A. Unsworth, "Selection for rehabilitation: Acute care discharge patterns for stroke and orthopedic patients". *International Journal of Rehabilitation Research*, vol. 24 pp. 103–114, 2001.
- [73] L. Brosseau, L. Potvin, P. Philippe, and Y.L. Boulanger. "Post-stroke inpatient rehabilitation: predicting discharge disposition", *American Journal of Physical Medicine and Rehabilitation*, vol. 75, pp. 431–436, 1996.
- [74] W. L. Hare, A. Alimadad, H. Dodd, R. Ferguson, and A. Rutherford, "A deterministic model of home and community care client counts in British Columbia", *Health Care Management Science*, vol. 12, no. 1, pp. 80–98, September 2008.
- [75] F. Lin, N. Kong, and M. Lawley, "Capacity Planning for Publicly Funded Community Based Long-Term Care Services", in *Community-Based Operations Research*, M. P. Johnson, Ed. New York, NY: Springer New York, vol. 167, pp. 297–315, 2012.
- [76] T. Cardoso, M. D. Oliveira, A. Barbosa-Póvoa, and S. Nickel, "Modeling the demand for long-term care services under uncertain information", *Health Care Management Science*, vol. 15, no. 4, pp. 3854–12, July 2012.
- [77] E. N. Weiss and J. O. McClain, "Administrative days in acute care facilities: a queuing-analytic approach", *Operation Research*, vol. 35, no. 1, pp. 354–4, February 1987.
- [78] N. Koizumi, E. Kuno, and T. E. Smith, "Modeling Patient Flows Using a Queuing Network with Blocking", *Health Care Management Science*, vol. 8, no. 1, pp. 49–60, February 2005.
- [79] J. Patrick, "Access to Long-Term Care: The True Cause of Hospital Congestion? " *Production and Operations Management*, vol. 20, no. 3, pp. 347–358, May 2011.
- [80] Y. Zhang, M. L. Puterman, M. Nelson, and D. Atkins, "A Simulation Optimization Approach to Long-Term Care Capacity Planning", *Operations Research*, vol. 60, no. 2, pp. 249–261, April 2012.
- [81] Y. Zhang and M. L. Puterman, "Developing an adaptive policy for long-term care capacity planning", *Health Care Management Science*, vol. 16, no. 3, pp. 271–279, March 2013.
- [82] Nova Scotia Community Counts, Community Profile, Population, 2011. Retrieved from:<http://www.novascotia.ca/finance/communitycounts/profiles/community/default.asp>

- [83] Nova Scotia Community Counts, Health Profile, District Health Authority, 2011. Retrieved from: <https://novascotia.ca/finance/communitycounts/profiles/health/profileac.asp>
- [84] Nova Scotia Department of Health and Wellness, Entering Long Term Care, Continuing Care, 2015.
- [85] B. Yang and J. Feng, "Two approaches for shortening the waiting time in a public health care system", *Hong Kong Polytechnic University, Hong Kong & Saint Mary's University, Canada*, (Working Paper), 2015.
- [86] F. Béland, H. Bergman, P. Lebel, A. M. Clarfield, P. Tousignant, A.P. Contandriopoulos et al, "A System of Integrated Care for Older Persons with Disabilities in Canada: Results from a Randomized Controlled Trial", *Journal of Gerontology*, vol. 61, no. 4, pp. 367–73, 2006.
- [87] A. Street, and A. Maynard, "Activity Based Financing in England: The Need for Continual Refinement of Payment by Results." *Health Economics, Policy and Law*, vol. 2, no. Pt. 4, pp. 419–27, 2007.
- [88] J. Keefe, and P. Fancey, "Home to Nursing Home. Understanding Factors that Impact the Path Seniors Take, Nova Scotia Centre in Aging", *Mount Saint Vincent University*, 2014.
- [89] Health Association Nova Scotia, An Inter-jurisdictional Comparison of Continuing Care Services in Canada, 2012.
- [90] Health Association Nova Scotia, A Comparison of Nova Scotia and British Columbia's Health Expenditures, April 2012.
- [91] Home Instead Senior Care Halifax, Understanding What Home Care Really Costs, 2011. Retrieved from: <https://www.homeinstead.com/3008/home-care-services>
- [92] Job Bank, Registered Nurses Nova Scotia, 2015. Retrieved from: <http://www.jobbank.gc.ca>
- [93] Home Care Ontario, Publically Funded Home Care, 2013. Retrieved from: <http://www.homecareontario.ca/home-care-services/factsfigures/publiclyfundedhomecare>
- [94] Job Bank, Doctors Nova Scotia, 2015. Retrieved from: <http://www.jobbank.gc.ca>
- [95] S. Ubelacker, MDs' gross income \$307,000, report finds, *The Globe and Mail*, 2013. Retrieved from: <http://www.theglobeandmail.com/life/health-and-fitness/health/mds-gross-income-307000-report-finds/article7640498/>
- [96] Ontario Home Care Association, Long Term Care Homes are Publically Funded, 2015.

- [97] Capital Health, Rooms and Services, 2015. Retrieved from: <http://www.cdha.nshealth.ca/patients-clients-visitors/preparing-your-hospital-stay/rooms-services>
- [98] C. Marshall, "Long Term Care Placement Process Review in DHA 9: Hospital to Nursing Home Placements", Health Association Nova Scotia, 2011.
- [99] Expert Panel on Alternative Level of Care, Appropriate level of care: a patient flow, system integration and capacity solution, 2006. Retrieved from [https://www.oanhss.org/oanhssdocs/Issue\\_Positions/External\\_Resources/ALC\\_Report\\_December\\_2006.pdf](https://www.oanhss.org/oanhssdocs/Issue_Positions/External_Resources/ALC_Report_December_2006.pdf)
- [100] Ministry of Health and Long Term Care, Discharge of Hospital Patients, Chapter 3: Section 3.02, Annual Report of the Office of the Auditor General of Ontario, 2010.
- [101] M. M. Kembe, E. S. Onah, S. Iorkegh, "A Study of Waiting And Service Costs of A Multi-Server Queuing Model In A Specialist Hospital", *International Journal of Scientific & Technology Research*, vol. 1, no. 8, pp. 19–23, 2012.
- [102] B. Render, R. M. Stair, and M. Hanna, *Quantitative Analysis for Management*, 9<sup>th</sup> ed. Upper Saddle River, NJ: Prentice Hall, 2006.
- [103] C. Ham, J. Dixon and C. Chantler, "Clinically Integrated Systems: The Future of NHS Reform in England? ", *British Medical Journal*, 342 (March): d905, March 2011.
- [104] I. Vedel, M. Monette, F.F. Beland, J. Monette and Bergman, "Ten Years of Integrated Care: Backwards. The Case of Province of Quebec, Canada", *International Journal of Integrated Care*, 11(Sep. Ed.): e004, March 2011.
- [105] M. J. Robertson, R. W. Broyles and A. Khaliq, "The Influence of Financial Incentives and Racial Status on the Use of Post Hospital Care", *Journal of Aging and Social Policy*, vol. 16, no. 4, pp. 17–38, 2004.
- [106] K. McGrail, M. Law and P. C .C . Hébert, "No More Dithering on e-Health: Let's Keep Patients Safe Instead", *Canadian Medical Association Journal*, vol. 182 no. 6, p. 535, 2010.
- [107] J. Beauchamp, V. Cheh, R. Schmitz, P. Kemper and J. Hall, "The Effect of the Program of All-inclusive Care for the Elderly (PACE) on Quality", *Princeton, NJ: Mathematica Policy Research*. Retrieved from: <http://www.cms.gov>
- [108] L. A. Meret-Hanke, "Effects of the Program of All-inclusive Care for the Elderly on Hospital Use", *Journal of Gerontology*, vol. 51 no. 6, pp. 774–85, 2011.
- [109] J. M. Sutherland, "Hospital Payment Mechanisms: An Overview and Options for Canada." *Ottawa: Canadian Health Services Research Foundation*, 2011.

[110] M. B. Buntin, C.H. Colla and J.J. Escarce, "Effects of Payment Changes on Trends in Post-Acute Care", *Health Services Research*, vol. 44, no. 4, pp. 1188–210, 2009.

[111] Health Association Nova Scotia, Cape Breton District Health Authority, and Nova Scotia Department of Health and Wellness, *Removing Barriers to Receiving Care at Home: A Perspective from the Cape Breton Region, Focusing on Hospital to Home*, April 2013.

[112] D. Walker, "Caring for our aging population and addressing alternate level of care: Report submitted to the Minister of Health and Long-term Care", Ontario Ministry of Health and Long-Term Care, June 2011. Retrieved from: <http://www.ontla.on.ca/library/repository/mon/25009/312292.pdf>

[113] R. Knowles, "New home care initiatives 2012/13", Continuing Care Branch, Department of Health and Wellness, Fall Forums 2012.

[114] A. P. Williams, D. Challis, R. Deber, J. Watkins, K. Kuluski, J. M. Lum, S. Daub, "Balancing institutional and community-based care: why some older persons can age successfully at home while others require residential long-term care". *Healthcare quarterly*, vol. 12, no. 2, pp. 95–105, 2009.

[115] E. Schultz, E, "The long-term care system in Denmark", *German Institute for Economic Research*, Berlin, 2010. Retrieved from: [http://www.diw.de/documents/publikationen/73/diw\\_01.c.359021.de/dp1038.pdf](http://www.diw.de/documents/publikationen/73/diw_01.c.359021.de/dp1038.pdf)

[116] J. Ross, "The patient journey through emergency care in Nova Scotia – A prescription for new medicine", Nova Scotia Department of Health, 2010. Retrieved from: <http://www.gov.ns.ca/health/emergencycarereport/docs/Dr-Ross-The-Patient-Journey-Through-Emergency-Care-in-Nova-Scotia.pdf>

[117] Canadian Life and Health Insurance Association Inc, CLHIA report on long-term care policy: Improving the accessibility, quality, and sustainability of long-term care in Canada, 2012. Retrieved from: [http://www.clhia.ca/domino/html/clhia/CLHIA\\_LP4W\\_LND\\_Webstation.nsf/resources/Content\\_PDFs/\\$file/LTC\\_Policy\\_Paper.pdf](http://www.clhia.ca/domino/html/clhia/CLHIA_LP4W_LND_Webstation.nsf/resources/Content_PDFs/$file/LTC_Policy_Paper.pdf)

## Appendix A: DHAs & Areas in Nova Scotia

<b>DHA Number (2014)</b>	<b>District Health Authority Name</b>
1	South Shore Health
2	South West Health
3	Annapolis Valley Health
4	Colchester East Hants Health Authority
5	Cumberland Health Authority
6	Pictou County Health Authority
7	Guysborough & Antigonish Strait Health Authority
8	Cape Breton District Health Authority
9	Capital Health

The 9 DHAs across NS were merged on January 1, 2015 to become: Nova Scotia District Health Authority (NSDHA). NSDHA contains 4 areas are represented in the table below.

<b>Area Number (2015)</b>	<b>Health Area Name</b>
1	South Shore Areas
	South West Areas
	Annapolis Valley Areas
2	Colchester East Hants Areas
	Cumberland Areas
	Pictou Areas
3	Guysborough & Antigonish Areas
	Cape Breton areas
4	Halifax, Eastern Shore & West Hants Areas

# Appendix B: Acronyms & Abbreviations

ABI: Acquired Brain Injury

AC: Acute Care

ALC: Alternative Level of Care

ALCCN: Alternative Level of Care & Community Care Network

CBO: Community Based Option

CC: Continuing Care

CCBP: Community Care Based Programs

CCS: Continuing Care Strategy

CIHI: Canadian Institute of Health Information

DHA: District Health Authority

DHW: Department of Health and Wellness

FCFS: First-Come-First-Served

FYTD: Fiscal Year to Date

GMG+: The Case Mix Group+

HC: Home Care

HCO: Health Care Organization

Inter RAI (CAPs): International Resident Assessment Instrument

Inter RAI (CAPs): Clinical Assessment Protocols

LOS: Length of Stay

LTC: Long Term Care

NH: Nursing Home

OECD: Organization for Economic Co-operation and Development

PAC: Poste Acute Care

PC: Palliative Care

RCF: Residential Care Facility

SH: Supportive Housing

# Appendix C: Definitions Glossary

**Acute Care:** A pattern of health care in which a patient is treated for a brief but severe episode of illness, as a result of an accident, trauma, or during recovery from surgery. Acute care is usually given in a hospital for only a short time.

**Alternative Level of Care:** Identifies a person who has completed the acute care phase of his or her treatment but remained in an acute care bed.

**Bed Vacancy Reporting Scenario:** A facility has 100 beds and in a 30 day month has 3000 available bed days. (Beds X days = available bed days). The facility reports 20 vacant bed days for the month. Occupancy rate =  $2980 \text{ utilized bed days} / 3000 \text{ available bed days} = 99.3\%$ . The occupancy rate alone does not provide information on the length of time an individual bed has been vacant. In this scenario, there could have been 1 bed vacant for 20 days, 4 beds vacant for 5 days, or other combinations that sum 20.

**For Profit Homes:** Facilities owned by an individual, organizations or corporations operating for a profit.

**Home Care:** Seniors living at home who need someone else to help with their activities of daily living including washing, dressing, eating or taking medication.

**Homes For The Aged:** Nursing homes, retirement homes, and other facilities providing services and care for the aged. Not included are homes for senior or lodges where no care is provided.

**Mental Health Facilities:** Facilities for persons with developmental delays, psychiatric disability, alcohol or drug problems and for emotionally disturbed children.

**Non-Profit Homes:** Federal, provincial, municipal, religious, lay (volunteer) institution operating for no profit.

**The Case Mix Group+ Methodology (CMG+):** Is designed to group acute care inpatients with similar clinical and resource-utilization characteristics. These broad categories are based generally on the diagnosis responsible for the greatest portion of the patient's length of stay).

**Tukey – Kramer Method:** Is a single-step multiple comparison procedure and statistical test. It can be used on raw data or in conjunction with an ANOVA analysis to find means that are significantly different from each other.